

Operator's Maintenance Manual
FOR
BUKH+BETA SOLAS 48 EPA
Marine Diesel Engine
Type BBV2203

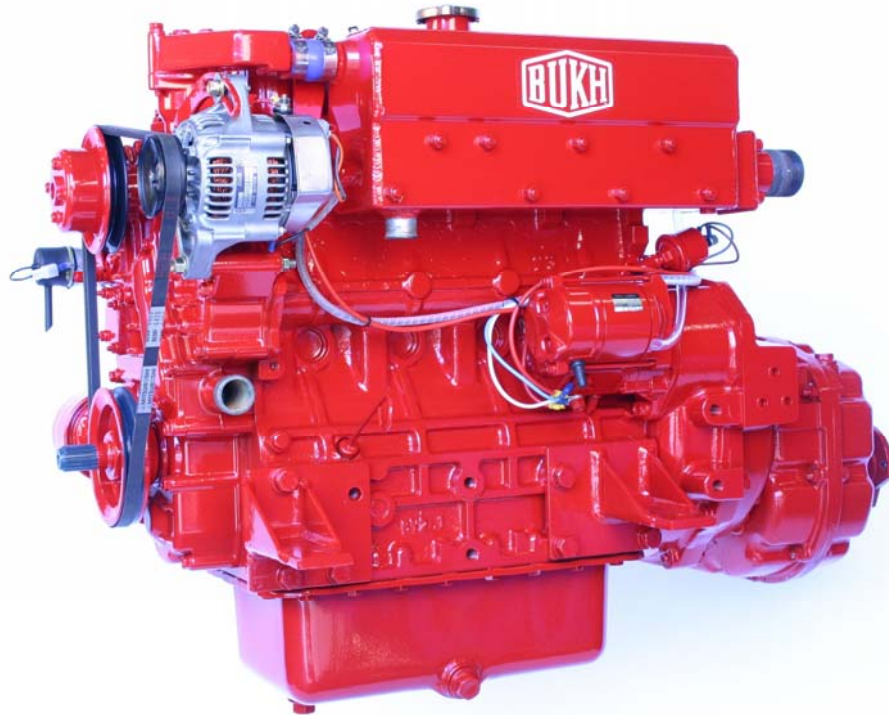

powering **marine** safety

Aabenraavej 13 - 17
DK 6340 Krusaa
Tel: +45 74 62 20 88
Fax: +45 74 62 74 07
E-mail: bukh@bukh.dk
www.bukh.dk

Engine Details

IMPORTANT - Please fill in details at moment of purchase – it really will help you! (and it will really help us specify the correct spare parts for you).

Engine Type:	Power:	bhp	Speed:	rpm
BETA WOC NO: K				
Gearbox Type:				
Purchased from:				
Invoice No:				
Date Commissioned:				
Specification / Special Details				

Contents

INTRODUCTION	3
Safety Information	4
TECHNICAL SPECIFICATION	5
SECTION 1: GUIDELINES FOR OPERATION OF ENGINE	
Initial Start-up and Bleeding The Fuel System	6
Starting / Stopping	7
SECTION 2: MAINTENANCE & SERVICE GUIDELINES	
Maintenance Schedule	8
Lubrication	9
Fuel System – Pumps, Filter, Fuel/water separator	10
Cooling – Keel Cooling	11
Belt Tensioning	13
Air Filter	13
Electrical	14
Laying up - Winterising	14
Troubleshooting	15
Torque Settings	26
SECTION 3: INSTALLATION	
Installation Guidelines	27
Engine Mounting	27
Alignment – Drives, Flanges, Flexible Drives	27
Mounting Exhaust	28
Fuel Supply	29
Cooling	30
Calorifier System	30
Electrical and Diagrams	31
Installation drawing	36
Declaration of Conformity	37
General Terms of Sale and Delivery	39

OPERATION AND MAINTENANCE MANUAL FOR THE FOLLOWING BUKH+BETA MARINE ENGINES BASED ON KUBOTA

BUKH+Beta 48 (BBV2203)

This manual has been compiled to provide the user with important information and recommendations to ensure a trouble free and economical operation of the engine.

For further advice or technical assistance, application should be made to BUKH, BETA MARINE LIMITED or our distributors.

All information and recommendations given in this publication are based on the latest information available at the time of publication, and are subject to alteration at any time. The information given is subject to the company's current conditions of Tender and Sale, is for the assistance of users, and is based upon results obtained from tests carried out at the place of manufacture and in vessels used for development purposes.

We do not guarantee the same results will be obtained elsewhere under different conditions.

ENGINE IDENTIFICATION

NOTE: In all communications with the distributor or Beta Marine, the **engine number, type, and W.O.C. number must be quoted.**



BETA MARINE LTD

Engine No..... XE5567
Engine Type... BV 1505
Woc..... K 234
Output..... 37.5bhp @ 3000RPM
Tel No..... (44) 01453 835282
Fax No..... (44) 01453 835284
Quote engine and WOC numbers for spares

BUKH+BETA 48

The engine serial number is stamped above starter motor on the port side of the engine, and is shown on the rocker cover label.

INITIAL RECEIPT OF THE ENGINE

A full inspection of the engine must be made **immediately on delivery** to confirm that there is no damage. If there is any damage then write this clearly on the delivery note and inform your dealer, BUKH or Beta Marine within 24 hours.

ENGINE STORAGE

The engine must be stored in a dry, frost free area and this is best done in its packing case. If storage is to be more than six months then the engine must be inhibited (contact your dealer or Beta Marine). Failure to inhibit the engine may result in the formation of rust in the injection system and the engine bores, this could invalidate the warranty.

SAFETY PRECAUTIONS!

A Keep the engine, gearbox and surrounding area clean, including the area immediately below the engine

B DRIVES - Power Take Off Areas

i) Gearbox Output Flange

The purpose of a marine diesel propulsion engine is to provide motive power to propel a vessel. Accordingly the gearbox output shaft rotates at between 133 and 2400 rev/min. This flange is designed to be coupled to a propeller shaft by the installer and steps must be taken to ensure adequate guarding.

ii) Forward End Drive

Engines are supplied with unguarded vee belt drives to power the fresh water pump and battery charging alternator. The installer must ensure that it is not possible for injury to occur by allowing accessibility to this area of the engine. The three pulleys run at high speed and can cause injury if personnel or clothing come in contact with the belts or pulleys, when the engine is running.

iii) Power Take Off Shaft (Engine Mounted Option)

Shaft extensions are available as an option and rotate at between 850 and 3600 rev/min. If contact is made with this shaft when the engine is running, injury can occur.

C EXHAUST OUTLET

Diesel marine propulsion engines emit exhaust gases at very high temperatures - around 400-500°C. Engines are supplied with either wet exhaust outlet (water injection bend) or dry outlet (dry exhaust stub) - see

option list. At the outlet next to the heat exchanger/header tank, the exhaust outlet can become very hot and if touched, can injure. This must be lagged or avoided by ensuring adequate guarding. It is the responsibility of the installer to lag the exhaust system if a dry system is used. Exhaust gases are harmful if ingested, the installer must therefore ensure that exhaust lines are lead overboard and that leakage in the vessel does not occur.

D FUEL

i) Fuel Lines

Diesel engines are equipped with high pressure fuel injection pumps, if leakages occur, or if pipes fracture, fuel at a high pressure can harm personnel. Skin must be thoroughly cleaned in the event of contact with diesel fuel.

ii) Fuel Supply Connections

Engines are supplied with 8 mm compression fittings. The installer must ensure that when connections are made, they are clean and free of leaks.

E OIL

The Beta propulsion is supplied with 2 dipsticks, one for the engine and one for the gearbox. Ensure dipsticks are returned and secure after checking, if not oil leaks can cause infection when touched. All oil must be removed from the skin to prevent infection.

F SCALDING

An engine running under load will have a closed circuit fresh water temperature of 85° to 95°C. The pressure cap on the top of the heat exchanger must not be removed when the engine is running. It can only be removed when the engine is

stopped and has cooled down.

G TRANSPORTATION/LIFTING

Engines are supplied on transportable pallets. Lifting eyes on engines are used for lifting engine and gearbox assembly only, not the pallet and associated kit.

GENERAL DECLARATION

This machinery is not intended to be put into service until it has been incorporated into or with other machinery. It is the responsibility of the purchaser/installer/owner, to ensure that the machinery is properly guarded and that all necessary health and safety requirements, in accordance with the laws of the relevant country, are met before it is put into service.

Signed:



J A Growcoot, C.E.O,
Beta Marine Limited

NOTE: Recreational Craft

Where applicable, the purchaser/installer/owner and operator must be responsible for making sure that the Recreational Craft Directive 94/25/EC is complied with.

TECHNICAL SPECIFICATIONS

STANDARD ENGINES

	BBV 2203
Cylinder	4
Bore (mm)	87
Stroke (mm)	92.4
Displacement (cc)	2197
Combustion	Spherical type (TVCS)
Cooling	Water
Starter voltage (V)	12
Starter output (kW)	1.4
Starter alternator output	45 (starter) & 2nd 150 (domestic)
Glow plug resistance (each)	1Ω
Engine speed (RPM)	2,800
Power output to ISO3046 (BHP)	50.0
Declared power ISO8665 (kW)	36.1
Compression Ratio	23.0:1
Fuel timing BTDC	18°
Capacity of standard sump approx (litres)	9.5
Nett dry weight with gearbox (kg)	300
Fuel	Diesel fuel oil No.2D
Coolant	33%-50% maximum antifreeze / water
Min. recommended battery capacity	12V 120Ah (600CCA Min)

Maximum Angle of Installation: Trim 15°, Roll 25° (intermittent), 20° continuous

Rotation: ANTI CLOCK ON FLYWHEEL, CLOCKWISE ON OUTPUT GEARBOX FLANGE FOR USE **WITH RIGHT HAND PROP IN AHEAD**, on mechanical gearboxes. Hydraulic gearboxes can be left or right handed.

Diesel fuel must conform to BS2869-1970 class A1 or A2. The fuel must be a distillate and not a residual oil or blend.

Lubricant: Engine - Engine oil must meet MIL-L-2104C (see section 2 for details)

Gearbox - see operator's manual for the gearbox oil type and capacity

Oil pressure - minimum (tickover) 0.5 bar

Power outputs: These comply with BS EN ISO 8665:1996 crankshaft power

Note: Declared Powers to ISO8665:1995

1. The declared powers are at the same engine speed as the ISO 3046 figures. This speed is the speed related to the outputs / powers shown.
2. Declared powers are at the gearbox coupling (coupling to the propeller shaft) as per clause 3.2.1 with standard specifications as per our current price lists. Additional accessories or alternative gearboxes may affect the declared powers.
3. Operation at parameters outside the test parameters may affect the outputs / powers which in any case are subject to the ISO tolerance bands.

SECTION 1

GUIDELINES FOR OPERATION OF ENGINE

IMPORTANT CHECKS PRIOR TO INITIAL USE

1. Generally, a new engine has the oil and anti-freeze removed after the works test. Fill the engine with the correct oil and anti-freeze (see sections on ENGINE OIL and COOLING). Check gearbox oil level - see separate operator's hand book.
2. Ensure the engine is free to turn without obstructions.
3. Ensure battery is fully charged and connected (the isolator is in the 'ON' position).

4. Ensure Morse speed and gearbox cables are fitted correctly and that cable travel lengths are correct.

Gear selection lever –all mechanical gearboxes: care must be taken to ensure that the remote control cable is adjusted so that the selector lever on the gearbox moves FULL travel and brought “hard up” against its end stop in both directions. Failure to achieve the correct adjustment will reduce efficiency of the clutch and may cause slippage at low revs.

Warranty will not be accepted on gearboxes returned in the warranty period for failure due to incorrect adjustment.

5. Ensure engine is out of gear with 1/3 throttle - see single lever control instruction manual.
6. Open the fuel stopcock and bleed the fuel water separator of air as shown in manufacturers literature.
7. Fuel should now be at the fuel lift pump, see diagram 1a.

INITIAL STARTUP AND BLEEDING THE SYSTEM

- (a) Open fuel bleed screw on top of fuel filter by 1 - 2 turns, see Fig 1a.
- (b) Move priming plunger on the fuel filter head up and down until fuel with no bubbles comes out of the bleed screw.
- (c) Shut/tighten the bleed screw.
- (d) Continue to hand prime for 10 seconds to push fuel through the fuel pump.
- (e) Start engine (see normal starting).

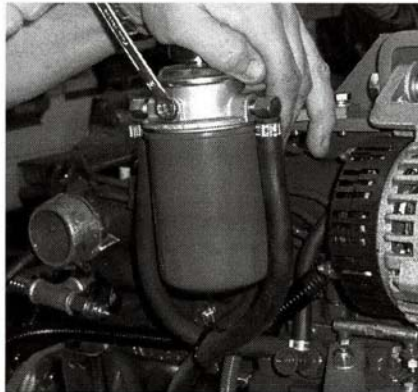

Diagram 1a

Note: the engine may have to be turned over with the starter for a few seconds before it fires. Do not run the starter for more than 20 seconds. If the engine has not started after 20 seconds then disengage the starter and continue to hand prime for a further 30 seconds, then repeat.

- (f) If engine does not start after 3 attempts then allow 5 minutes for the starter to cool down before repeating (b) to (e).

Note: The starter windings can be burnt out with continuous cranking

CAUTION

To avoid personal injury:

- Do not bleed a hot engine as this could cause fuel to spill onto a hot exhaust manifold creating a danger of fire.
- Do not mix gasoline or alcohol with diesel fuel. This mixture can cause an explosion.
- Do not get diesel on the flexible mounts – they will deteriorate rapidly if soaked in diesel.
- All fuel must be removed from skin to prevent infection.

NORMAL STARTING

With the engine out of gear, set speed control lever to 1/3 throttle. Put the "OFF/RUN" switch to 'RUN' position and wait for ten seconds. At this stage instrument panel should illuminate, an alarm buzzer will sound and the warning lights will illuminate:

STARTER BATTERY CHARGE OIL PRESSURE

Then push the "START" button and engine will motor, hold in position until engine fires (see initial start-up section for maximum time starter can be used).

Ensure alarm buzzer is not sounding and warning lights are extinguished. If the alternator warning light is still on, then increase engine speed to excite the alternator - then return to idle. The battery charge light should then go out.



STOPPING

Every propulsion engine is fitted with a stop solenoid which is energised to stop. To stop engine push the "STOP" button, hold in until engine stops, then put the "OFF/RUN" switch to 'OFF' position.

When leaving the boat for an extended period,

- Turn off battery isolator.

*WARNING

Do not push the "STOP" button for more than 10 seconds - as this will lead to overheating and failure of the solenoid.

This GreenLine range of engines are equipped with a mechanical stop lever in the event of electrical system failure. This lever is located on the starboard side of the engine below

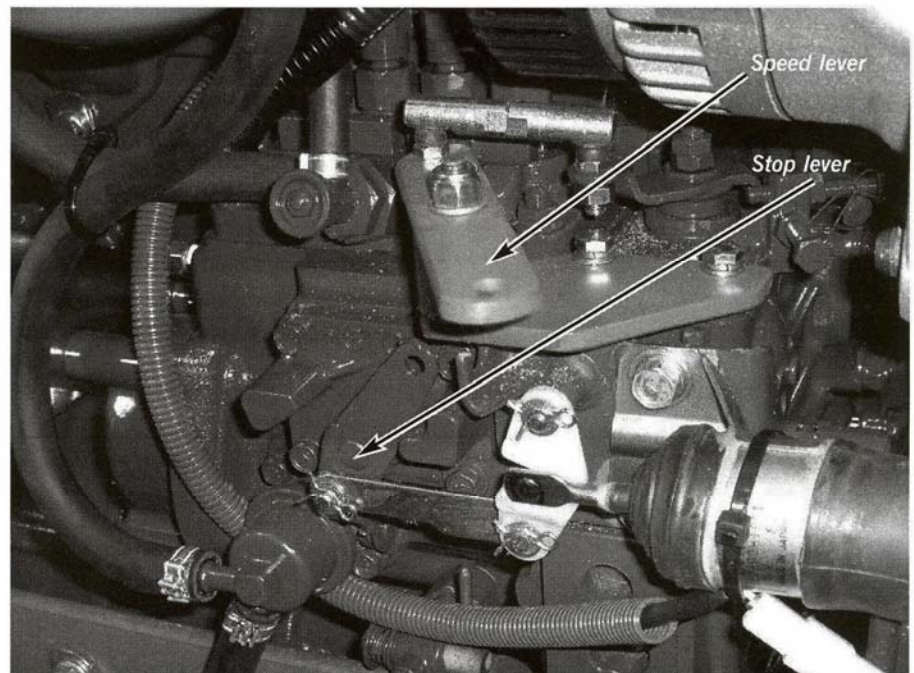

SECTION 2

MAINTENANCE SCHEDULE

DAILY OR EVERY 8 HOURS RUNNING

- Check engine oil level.
- Check gearbox oil level.
- Check coolant level.
- Check battery fluid.
- Check drive belt tension
- Check stern gland lubrication.
- Drain off any water in fuel water separator.

AFTER THE FIRST 25 HOURS RUNNING

- Change gearbox lubricant (See separate gearbox manual).
- Check that all external nuts, bolts and fastenings are tight. See table for torque values. Special attention should be paid to the flexible mount lock nuts, these should be checked for tightness, starting with lower nut first in each case. If the lower nuts are found to be very loose, then the alignment of the shaft to the gearbox half coupling should be re-checked. Poor alignment due to loose flexible mount nuts will cause excessive vibration and knocking.
- Check the belt tension on any second alternators fitted and adjust – see page 12.
- Check ball joint nyloc nuts for tightness on both gearbox and speed control levers. Grease both fittings all over.

AFTER FIRST 50 HOURS

- Change engine lubricating oil.
- Change oil filter.
- Drain off any water in fuel/water separator.

EVERY 150 HOURS

- If shallow sump (option) is fitted, change engine lubricating oil and filter.

EVERY YEAR -OR EVERY 250 HOURS IF SOONER

- Change engine lubricating oil (standard sump)
- Change lubricating oil filter
- Check air cleaner element
- Spray the key switch with WD40 or equivalent to lubricate the barrel.
- Check that all external nuts, bolts and fastenings are tight. See table for torque values.
- Check ball joint nyloc nuts for tightness on both gearbox and speed control levers. Grease both fittings all over.

EVERY 750 HOURS

- Change fuel filter.
- Change antifreeze.
- Change gearbox oil.
- Check electrical equipment, condition of hoses and belts, replace as necessary.

LUBRICATION

Engine oil: Engine oil quality should have the minimum properties of the American Petroleum Institute "API" classification CF (CD, or CE). The following table gives grades of oil viscosity required for various ambient temperature ranges. **Note:** A good quality SAE 15W/40 mineral based multigrade oil as used in most car diesel engines will meet requirements. Do *not* use 'Turbo Diesel Oil' or additives, and the use of synthetic oil is not recommended.

1. To check the oil level, draw out the dipstick, wipe it clean, reinsert it, and draw it out again. Check to see that the oil level lies between the two notches.
2. If the level is too low, add new oil to the specified level - Do *not* overfill.

old oil. Never mix two different types of oil. Engine oil should be changed after first 50 hours running time and then: every year or every 250 hours if sooner with a standard sump; a shallow sump is every year or every 150 hours if sooner. Oil filter is a cartridge type mounted on the port side of the engine.

IMPORTANT

When using an oil of different make or viscosity from the previous one, drain

CHECKING ENGINE OIL LEVEL

For quantities of oil required see section marked 'Technical Specification', Page 4. When checking the engine oil level, do so before starting, or more than five minutes after stopping.

SAE Grade of Lubricating Oil Viscosity		
AMBIENT TEMP	SINGLE GRADE	MULTI GRADE
-30°C to 0°C	SAE 10W	SAE 10W/30
-15°C to +15°C	SAE 20W	SAE 15W/40
0°C to +30°C	SAE 30	SAE 15W/40
25°C and above	SAE 30	SAE 15W/40

CHANGING ENGINE OIL

- (1) Run the engine for 10 minutes to warm up the oil.
- (2) Your engine is provided with a sump drain pump. Unscrew the end cap on the end of the pump, turn the tap to 'on'. Use the hand pump as shown to pump out the oil into a bucket. Turn the tap to off position and replace end cap. See diagram 2c.

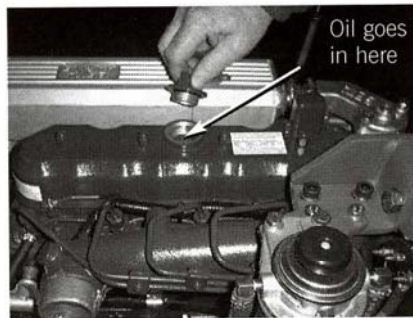

Fig. 2a

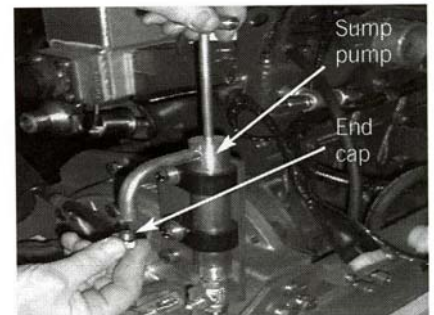

Fig. 2c

- (3) Unscrew the oil filter and replace with a new one. See diagram 2d.

Note: It is best to have a plastic bag wrapped round the filter to catch any oil left in the system. (Always keep your bilges clean!) Before screwing in the new filter spread a thin film of oil round the rubber gasket to ensure a good seal and screw in – hand tight.



Fig. 2b. Dip stick



Fig. 2d

- (4) Fill the engine with new oil as described above.
- (5) Run the engine and check for leaks.

CHECKING GEARBOX OIL LEVEL

- (1) The gearbox is fitted with a dipstick and oil filler plug, see fig 2e.
- (2) Each engine is supplied with a gearbox operators manual which specifies the type of lubricating oil to be used, the capacity and frequency of changing of the oil.
- (3) New engines are normally supplied with the gearbox topped up with lubricant but Check the level before starting the engine for the first time.
- (4) The oil can be changed via the drain plug at the bottom of the box or sucked out with a hand pump via the filler plug.
- (5) A guide to the type of oil to be used is as follows:

Gearbox	Lubricant	Capacity (approx)
PRM120	Use Engine Oil 15W40	0.8 litres
PRM150	Use Engine Oil 15W40	1.4 litres
PRM260	Use Engine Oil 15W40	1.5 litres



Fig 2e - Gearbox filler

FUEL SYSTEM (see page 28 for a typical installation)

IMPORTANT

- Always fit a fuel/water separator in the fuel supply system. **Water in the fuel can seriously damage the injection system.**
- If a fuel supply shutoff valve is fitted do not use a taper tap, only use a ball valve tap. The ball valve type are more reliable and less likely to let air into the fuel system.
- Be sure to use a strainer when filling the fuel tank. Dirt or sand in the fuel may cause trouble in the fuel injection pump.
- Always use diesel fuel.
- **Do not use kerosene** which is very low in cetane rating, and adversely affects the engine.
- Be careful not to let the fuel tank become empty, or air can enter the fuel system, necessitating bleeding before next engine start.
- The fuel lift pump will only lift fuel through 0.25 metres. If this is insufficient then an electric fuel lift pump must be fitted.

FUEL FILTER REPLACEMENT

1. The fuel filter is a spin on type. Remove by turning anti-clockwise when viewed from below.
2. Replace the fuel filter cartridge every 750 hours. See fig. 2g.
3. Apply fuel oil thinly over the gasket and tighten into position - hand tight.
4. Bleed as detailed - see initial start up.
5. Check for leaks.
6. **Do not get fuel on the flexible mounts.**

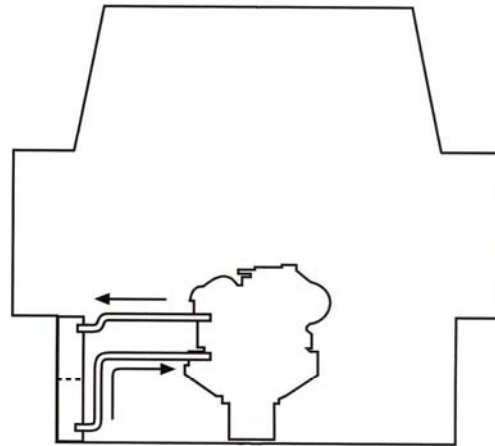
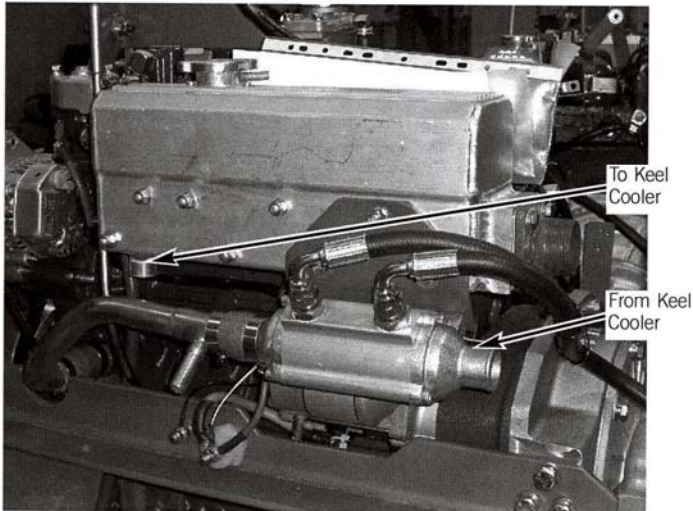

Fig. 2g

COOLING

KEEL COOLED

In this system the freshwater is pumped through the engine and then through a cooler built into the side of the boat where it is cooled by heat transfer before returning to the engine .



Keel Cooled -Note efficient cooling tanks are side mounted, see page 29.

FILLING THE FRESHWATER SYSTEM

New engines are supplied with the freshwater drained off. The following instructions must be followed to fill the system.

- (a) Mix up in a clean bucket the correct strength of solution (see page 11). For the volume required see technical specification consult with boat builder.
- (b) Check that the drain tap or plug is turned off. (see fig 2l)
- (c) Fill engine with freshwater/anti freeze solution through the top of the header tank with the filler cap removed. (see fig 2m).
- (d) Fill header tank to the top of the filler neck and replace cap.
- (e) Run the engine for 5 minutes on no load (out of gear) and check coolant level. Top up as necessary.
- (f) Check system for leaks.
- (g) If a calorifier is fitted care must be taken to see that this is also full of coolant and all the air is expelled. (See calorifier fitting notes under Section 3).
- (h) Run the engine on one third load for 15 minutes, preferably with the boat tied up. As the system warms up coolant may be expelled from the overflow pipe into the bilge. Stop the engine and allow the engine to cool down before removing the pressure cap and top up the coolant to 1" below the filler neck.

Note: For keel cooled engines a large quantity of freshwater/anti-freeze solution is required depending on the size of the keel cooling tank – refer to the builder, we recommend a 30% antifreeze/water ratio.

Note: For keel cooled engines it is very important to bleed all the air out of the system before the engine is run on load (check with builder's instructions).

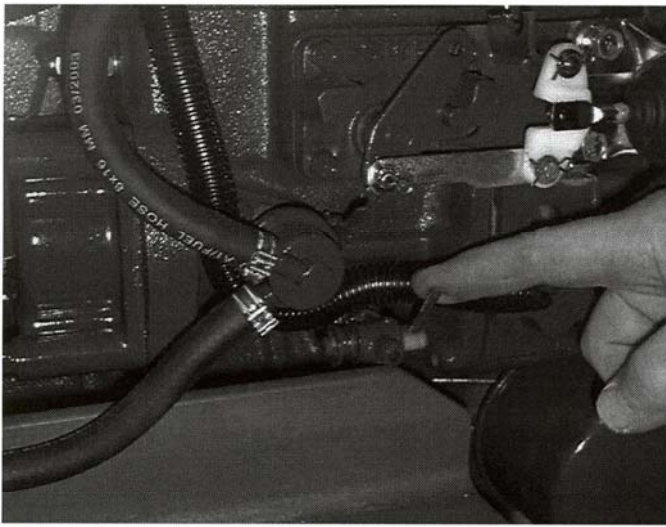

Fig. 2l



Fig. 2m

IMPORTANT

Removal of the pressure cap when the engine is hot can cause severe injury from scalding hot water under pressure. Always allow the engine to cool and then use a large cloth when turning the cap anti-clockwise to the stop. This allows the pressure to be released. Press firmly down on the cap and continue to turn anticlockwise to release the cap.

- (i) Repeat (h) if coolant level is more than 1 inch below the base of the filler neck when the engine has cooled down.
- (j) Run engine on 2/3 full load for 20 minutes, check for leaks and repeat (i).
- (k) Anti-freeze solutions should be drained off every 2 years and replaced with a new solution.

Note: When draining fresh water system, ensure the engine has cooled sufficiently to prevent scalding from hot pressurised water. Prior to draining a cold engine, remove the filler cap from the header tank and then open the water drain tap. This allows the water to drain freely from the system.

BOATS WITH KEEL COOLER

A 33% anti-freeze to water mixture is recommended to give protection against very cold winter temperature of minus 15°C. This anti-freeze will also give the engine internal protection against corrosion. For keel cooled engines the total system capacity must be taken into consideration, ie engine volume plus skin tank/keel cooler volume.

Concentration of ethylene should not exceed 50%.

The warranty is invalid unless the correct ratio is used.

The anti-freeze in the fresh water system enables the boiling point of water to rise to 124°C with a 13 psi pressure cap fitted. The water temperature alarm switch will however be activated at 95° to 100°C. If no anti-freeze or a very weak solution is used, then the water temperature switch may not be activated before coolant is lost.

BELT TENSION

40 & 150 AMP ALTERNATOR

WARNING

Belt tension must only be checked with the engine switched off.

(1) The GreenLine standard range of engines are fitted with a single belt to drive the 45 amp battery charging alternator and the fresh water circulating pump. A second 150 amp alternator is fitted for charging domestic batteries.

(2) The belt tension is adjusted by swinging the alternator outboard as it pivots on its support bolts.

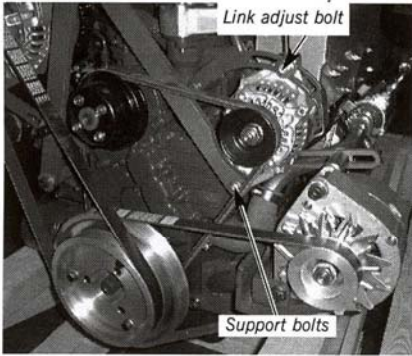

Fig. 1 - Alternator Belt Tensioning

(3) With the engine stopped, loosen the support bolts and the link adjusting bolt.

(4) Push alternator outboard to tension and tighten link bolt. Check that the depression of the belt at position shown is approximately $\frac{1}{2}$ " or 12 mm when pushed down firmly by thumb. Tighten support bolts.

(5) Belt tension should be regularly checked especially during the first 20 hours of running in a new belt, as stretching occurs.

Note: Over tensioning will cause premature failure of components.

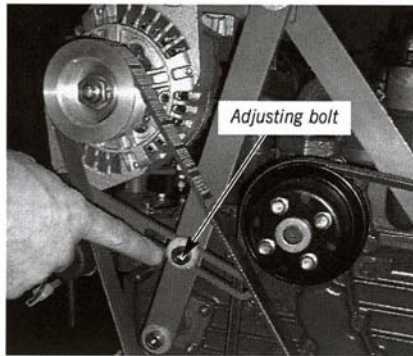

Fig. 2 - Alternator Belt Tensioning

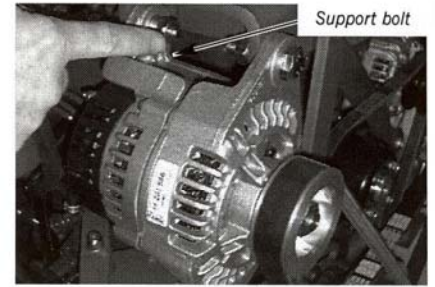

Fig. 3 - Alternator Belt Tensioning

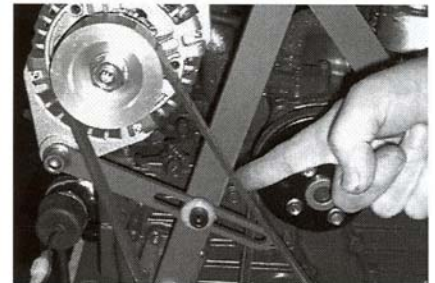

Fig. 4 - Alternator Belt Tensioning



Fig. 5 - Alternator Belt Tensioning

AIR INTAKE FILTER

These engines are fitted with a wire gauze filter to be rinsed in petrol and cleaned by a blast of compressed air after 300 hours' operating.

MAINTENANCE - ELECTRICAL



Under no circumstances should the battery be disconnected or switched off when the engine is running. This will seriously damage the alternator

PANELS AND WIRING

See installation notes, page 30.

GENERAL MAINTENANCE

- (1) The panel must be protected from rain and sea water, see installation. Sea water entering the key switch will eventually cause corrosion and could result in the starter motor being permanently energised and burning out. Spray key switch every month with WD40 or equivalent.
- (2) Check batteries for acid level and top up if required. For low maintenance and 'gel' batteries see manufacturers instructions.
- (3) Loose spade terminal connections are the most common cause for electrical faults - check on a regular bases (see maintenance instructions).

WINTERISING AND LAYING UP

LAYING UP BOATS WITH KEEL COOLING

Special care must be taken to ensure that the whole cooling system has a minimum 30% anti-freeze solution and this includes the calorifier circuit.

- (a) The engine oil and oil filter should be changed at the end of the season rather than the spring. See section 2.
- (b) The closed circuit system should contain a 50/50 solution of anti-freeze maximum, 30/70 minimum.

(c) Ensure instrument panel is well protected and give the key switch a spray of WD 40 or equivalent.

- (d) With the engine stopped, disconnect the batteries (always disconnect negative cables first / reconnect negative cables last) and take them ashore for trickle charging and top up as necessary. If AC power is available then this can be done on the boat.

(e) Fuel tanks should be kept full during the lay up period to eliminate water condensation in the tank. Water entering the fuel injection system can cause considerable damage.

If the system has been topped up or refilled then run the engine for 10 to 15 minutes on load (if possible) to get the solution circulated throughout the cooler and calorifier.

TROUBLE SHOOTING

Beta diesels are very reliable if installed and serviced correctly, but problems can occur and the following list gives the most common ones and their solution.

PROBLEM ENGINE DOES NOT START BUT STARTER MOTOR TURNS OVER OK

Possible Cause	Solution
No fuel:	Turn fuel cock on and fill tank.
Air in fuel system:	Vent air (see initial start-up)
Water in fuel:	Change fuel filter and bleed system.
Blocked fuel pipe:	Clean out and bleed system.
Fuel filter clogged:	Change filter and bleed system.
Fuel lift pump blocked:	Remove and replace.
Blocked injector:	Remove and clean.
Fuel return not fed back to the tank:	Re-route fuel return pipe.
Heater plugs not working:	Check wiring to the plugs, and replace plugs if they are burnt out.
Stop solenoid stuck in off position.	Check solenoid is free to return to run position.

PROBLEM: STARTER MOTOR WILL NOT TURN OR TURNS OVER VERY SLOWLY

Possible Cause	Solution
Battery discharged:	Charge battery or replace. Check alternator belt tension.
Starter motor flooded with sea water:	Remove and clean or replace.
Wiring disconnected or loose:	Check circuit for loose connections.
Water in cylinders:	Incorrect installation. This is serious - check engine oil for signs of water (creamy-coloured oil). Ring your dealer.
Engine harness fuse blown:	Replace fuse (located by starter motor or above flywheel housing) and check for wiring faults

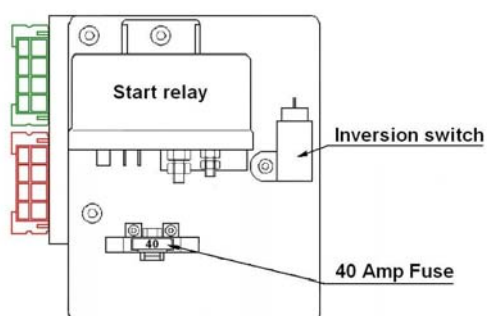

PROBLEM: ERRATIC RUNNING

Possible Cause	Solution
Air in fuel supply:	Check supply system for leaks and fix.
Fuel lift pump faulty:	Replace.
Clogged fuel filter:	Replace.
Fuel return not fed back to the fuel tank, or blocked pipe:	Re-route pipe or clean.
Air filter blocked:	Clean.
Worn or blocked injector:	Service injectors.
Engine rpm in gear is too low, this must be 850 min:	Increase engine tick over speed.
Faulty stop solenoid:	Disconnect wiring to solenoid. If running improves check for a wiring fault.
Broken fuel injection pump spring:	Replace.

PROBLEM: WHITE OR BLUE EXHAUST GAS

Possible Cause	Solution
Engine oil level too high:	Reduce the level.
Blocked injector:	Service injectors.
Piston ring and bore worn, giving a low compression:	Get compression checked by your dealer or Kubota service agent. He will advise action to be taken.
Check that the breather pipe is clear and not obstructed:	Remove and clean out.

PROBLEM: BLACK EXHAUST GAS

Possible Cause	Solution
Blocked air filter element	Inspect and replace
Over pitched propeller - engine will not reach its full rpm:	Get the propeller re-pitched if necessary.
Accumulated debris on hull	Inspect and clean if required

PROBLEM: LOW POWER OUTPUT

Possible Cause	Solution
Propeller is too big:	Change or depitch.
Check gearbox reduction ratio relative to propeller size:	Change.

PROBLEM: LOW POWER OUTPUT

Possible Cause	Solution
Blocked fuel filter:	Replace.
Blocked air filter:	Clean.
Air in fuel system:	Check system.
Governor spring incorrectly mounted:	Dealer to adjust.
Single lever control not operating correctly:	Disconnect speed control cable and move the lever by hand. Adjust cable.
The electrical load is too large on start up.	Disconnect or reduce the load.

PROBLEM: HIGH OIL CONSUMPTION

Possible Cause	Solution
Oil leaks:	Check for leaks.
Piston rings worn:	Overhaul required.
Valve stem and guide worn:	Overhaul required.
Piston rings gap facing the same direction:	Shift ring gap position.

PROBLEM: WATER IN LUBRICATING OIL - (Heat exchanger cooled)

Possible Cause	Solution
Oil goes "milky" due to sea water entering exhaust manifold:	Check installation - has anti-siphon valve been fitted? Change engine oil and run engine for 10 minutes each time to eliminate any water. Get fuel injection pump and compression checked by Service Agent.

PROBLEM: WATER IN LUBRICATING OIL - (General)

Possible Cause	Solution
Core plug pushed out due to frozen block:	Service Agent to check and replace.
Water pump seal damaged	Service Agent to check and replace.

PROBLEM: WATER IN LUBRICATING OIL - (Keel cooled)

Possible Cause	Solution
Oil goes "milky" due to water entering exhaust manifold and then into the sump:	Check installation – has dry exhaust system been fitted correctly, ensuring rain water cannot enter the exhaust port and run back? (See DRY EXHAUST SYSTEM) Change engine oil and run engine for 10 minutes each time to eliminate any water. Get fuel injection pump checked by Service Agent.

PROBLEM: LOW OIL PRESSURE WARNING LIGHT comes on when engine speed reduced to tick over:

Possible Cause	Solution
Faulty switch sender:	Replace.
Engine running too hot:	Check cooling water flow (see section 2 Cooling).
Oil relief valve stuck partially open with dirt:	Remove and clean.
Blocked oil filter:	Change.
Wiring fault:	Check circuit.
Insufficient oil:	Top up and check for leaks.

PROBLEM: PANEL REV COUNTER NOT WORKING (WHEN FITTED)

Possible Cause	Solution
No W connection to alternator.	Check power output from 'W' connection. Should be about 9V AC.
Wiring fault:	Check circuit.

PROBLEM: ENGINE OVERHEATS

Possible Cause	Solution
Check coolant level:	Top up.
Insufficient sea water flow:	Clear blocked intake or filter.
Damaged or worn pump impeller:	Replace.
Blocked tube stack in heat exchanger:	Remove tube stack and clean - replace 'O' rings.
Zinc anode flakes blocking tube stack:	Remove and clean tube stack as above.
Pressure cap loose:	Replace.
Switch sender faulty:	Replace.
Inlet sea cock is too small:	Replace (see heat exchanger cooled seawater inlet system in section 3).
High exhaust back pressure:	Must not exceed 3.1" of Hg.
Air locks in cooling pipe work to keel cooler:	Vent the system and top up coolant.
Keel cooler of insufficient size:	Contact boat builder.

GENERAL -HEAT EXCHANGE ONLY:

The most common cause of overheating is insufficient seawater flow due to a blocked intake (weed or a plastic bag!). If this happens then clear the blockage. If the problem is not cured then check the system for sea water flow which should be 6.5 litres / minute minimum at 1,000 rpm as follows:

(a) With the boat tied up and out of gear run the engine up to 1000 rpm.

*Hold a plastic bucket over the

exhaust outlet for 10 seconds and measure the amount of water collected. Multiply this value by 6 to give the flow in litres/min. Repeat twice and take an average. If the flow rate is noticeably less than the 6.5 litre per minute minimum, then:

(b) Check impeller in sea water pump - if worn replace.

(c) If impeller has a vane missing then this will be lodged either in the

pipe to the heat exchanger or in the end of the exchanger. This must be removed.

(d) Check flow again as in (a).

***Note:** This operation must only be done in safe conditions, in port and with two assistants.

Working from a rubber dinghy is best. The person holding the bucket should take precautions against breathing in the exhaust gasses.

PROBLEM: KNOCKING NOISE

Possible Cause	Solution
Propshaft touching gearbox output coupling through split boss or Type 16 coupling:	Adjust, giving correct clearance (10mm) between gearbox and propeller shaft.
Flexible mount stud touching engine bed:	Adjust stud to clear.
Drive plate broken:	Replace / repair.
Engine touching engine bed:	Re-align engine / modify bed.

PROBLEM: BATTERY QUICKLY DISCHARGES

Possible Cause	Solution
High load and insufficient running:	Reduce load or increase charging time. Large domestic batterybanks subject to high electrical loads will take a considerable time to recharge from a single alternator.
Low electrolyte level:	Top up.
Fan belt slipping - black dust in engine compartment: Engine compartment temperature too high.	Adjust tension / replace belt with a high temperature and/or improve engine box ventilation.
Alternator defective:	Check with Agent.
Battery defective:	Replace.
Poor wiring connection:	Check wiring system.

PROBLEM: TRANSMISSION NOISE

Possible Cause	Solution
Check gearbox oil level:	Top up.
"Singing" propeller:	Check with supplier.
Drive plate rattle at tickover:	Check engine rpm (must be 850 rpm minimum in gear).
Worn drive plate:	Change.
Propellor shaft hitting the gearbox half coupling	Move shaft back to give at least 5mm clearance (type 12/16 couplings only)

PROBLEM: VIBRATION

Possible Cause	Solution
Poor alignment to shaft:	The alignment must be accurate even if a flexible coupling is used (see section 3 ALIGNMENT).
Flexible mounts not adjusted correctly to take even weight:	Check relative compression of each mount.
Flexible mount rubber perished:	Replace. (Diesel or oil will eventually perish most rubbers.)
Loose securing nut on flexible mount:	Check alignment and then tighten the nuts.
Insufficient clearance between the propeller tip and the bottom of the boat:	There must be at least 10% tip clearance between propeller and bottom of the boat (ie 10% of the propeller diameter as clearance). Refer to boatbuilder.
Loose zinc anode on the shaft:	Tighten or replace.
Worn cutless bearing or shaft:	Replace.
Weak engine support/bearers:	Check for cracked or broken feet.

PROBLEM: MORSE CONTROL CABLE WILL NOT FIT

Possible Cause	Solution
Fitting incorrectly	Cables are being fitted the wrong way around, switch over and fit the opposite way.

ELECTRICAL FAULT FINDING & TROUBLE SHOOTING

The following chart is compiled to aid diagnosis of electrical faults, based on the Beta 28-48 hp range of engines.



Standard sea specification engines are supplied with a single alternator, mounted port side, supplying power to starter battery and control panel.

Standard control panels are supplied with three lamps, these panels utilise bulbs inside sealed lamp holders.

With the "OFF/RUN" switch in 'RUN' position & engine off:

- Red lamp for no starter battery charge should function
- Yellow lamp for low oil pressure should function
- Green lamp for high engine temperature should not function (when engine is cold / cool / warm). This lamp will only ever function if the engine is over temperature.
- Buzzer should sound

All BUKH panels have the following warning lamps:

• Starter battery charge warning lamp		Red
• Low engine oil pressure warning lamp		Yellow
• High engine temperature warning lamp		Green

When the engine is started, all the warning lamps should switch off. The oil pressure lamp may take a few seconds to switch off and the charge fail lamp may remain on until engine rpm is increased to approximately 1,000rpm if the engine was started at tickover)

Before investigating any specific electrical problem, always check:

- Connection between panel harness and panel loom. It must be clean, dry and secured with a cable tie.
- Check the start battery is connected to the correct terminal on the starter motor.

- Battery connections, inspecting condition of cables from battery to engine. If in doubt measure the voltage at the engine.
- If alternator charge problem, measure battery voltage with engine off and again with engine running, if there is an increase alternator is functioning correctly, if not refer to check list.

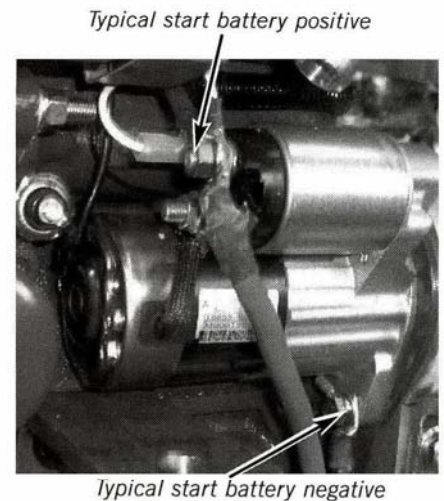

ELECTRICAL FAULT FINDING –ALL LAMP PANELS

PROBLEM	POSSIBLE CAUSE & SOLUTION
No warning lamps or buzzer functioning, engine will not start or stop	<ul style="list-style-type: none"> • Battery isolation switch in off position –switch on • Starter battery discharged – charge • Engine fuse blown –check fuse (above starter motor or flywheel housing) & replace if necessary. • Check for wiring faults.
<p>Non function of warning lamp</p> <p>THE WATER TEMPERATURE WILL NOT FUNCTION UNLESS ENGINE IS OVERHEATING OR THERE IS A WIRING FAULT</p>	<ul style="list-style-type: none"> • Disconnect switch wire to non-functioning lamp: violet –water temperature, brown –oil pressure, grey –alternator charge. Reconnect wire temporarily to another warning lamp that is functioning; if wire switches lamp on replace faulty lamp. • Disconnect positive feed to non-functioning lamp. Reconnect temporarily with wire from another warning lamp that is functioning, if wire switches lamp on rewire with new connection. • If none of the above, check continuity of connections from panel to engine.
Water temperature warning LED on when engine is not over temperature	<p>If engine is cold:</p> <ul style="list-style-type: none"> • Faulty wiring, check connection & continuity (violet) from switch to panel lamp. Ensure this connection is not shorting to earth (ground). • Faulty temperature switch –if lamp switches off on removal of connection to switch unit, replace. <p>If engine is warm:</p> <ul style="list-style-type: none"> • Switch wire connected to large sender terminal of switch / sender unit. Remove and refit to smaller (switch) terminal
<p>Buzzer not functioning</p> <p>THE BUZZER WILL NOT SOUND</p>	<ul style="list-style-type: none"> • If lamp is functioning but buzzer not sounding, check connection & continuity from illuminated warning lamp (white) to buzzer board. • Faulty warning panel buzzer board –replace.
Starter battery charge lamp not functioning	<ul style="list-style-type: none"> • Alternator not connected properly, check continuity of grey/(number 5) from rear of alternator to terminal '8' on distributor plate. • alternator connected properly, faulty alternator –replace • Check continuity of small (grey) wire from terminal '7' on distributor plate to charge warning lamp on rear of panel. • If alternator connected properly, faulty panel warning lamp –replace
Tacho not functioning	<ul style="list-style-type: none"> • -Check connections on rear of tacho, especially wire (number 5), terminal '4' • -Check connection of orange wire on rear of alternator (W connection, usually a bullet on flying lead, or lowest connection on alternators with 3 pin coupler) • -Check continuity of orange/(number 5) wire from alternator to tacho • -Measure voltage from alternator W connection to earth (ground), should be approx. 7.5 – 9.0 volts AC

ELECTRICAL FAULT FINDING & WATER TEMPERATURE FUNCTION ON PANELS

In addition to the fault finding detailed on the previous table, the following is specific for the instrument panel

PROBLEM	POSSIBLE CAUSE & SOLUTION
Oil pressure warning lamp not functioning, oil pressure gauge showing maximum deflection. Engine off and keyswitch in run position	<ul style="list-style-type: none"> Faulty wiring –check wire connection & continuity (brown) from sender to panel lamp. Ensure this connection is not shorting to earth (ground).
Oil pressure gauge showing no movement - even when engine is started. Warning lamp functioning correctly	<ul style="list-style-type: none"> Faulty wiring –check oil pressure sender wire (grey) is connected.
Oil pressure showing no movement, Warning lamp not functioning correctly	<ul style="list-style-type: none"> Check connection to oil pressure gauge, if plug is not connected to socket on rear of gauge reconnect. If all connections are correctly made, possible faulty sender unit –check resistance to earth (ground) approx. 50Ω. Replace if no reading or short-circuited. If adjusted correctly & buzzer still sounding, possible faulty switch gauge unit – replace.
Oil pressure showing normal operating pressure (0.75–5 bar). Buzzer sounding & lamp illuminated.	<p>Engine warm:</p> <ul style="list-style-type: none"> Incorrectly calibrated switching point for warning lamp, adjust on rear of gauge to 0.5 bar (minimum adjustment on gauge). If adjusted correctly & buzzer still sounding, faulty switch gauge unit – replace.
Water temperature gauge showing 120°C / 250°F	<p>Engine cold / cool:</p> <ul style="list-style-type: none"> Faulty wiring, check water temperature sender wire is not shorting to earth (ground). Faulty sender unit, –check resistance to earth, approx. 3.5kΩ (cold) – 0.5kΩ (warm). Replace if notably less.
Water temperature gauge showing normal operating temperature (85°C). Buzzer sounding & lamp illuminated.	<p>Engine warm:</p> <ul style="list-style-type: none"> Incorrectly calibrated switching point for warning lamp, adjust on rear of gauge to 100°C/210°F. If adjusted correctly & buzzer still sounding, faulty switch gauge unit – replace.
Water temperature gauge showing no movement, lamp not illuminated, engine warm.	<ul style="list-style-type: none"> Check connection to sender, if disconnected gauge will not function. Check connection to temperature gauge, if plug is not connected to socket on rear of gauge reconnect. If all connections are correctly made, faulty sender unit –check resistance to earth, approx. 3.5kΩ (cold) – 0.5kΩ (warm). Replace if no reading.

ELECTRICAL – CORRECT OPERATION OF CONTROL PANELS

These panels control the engine with two water resistant push buttons for 'START' and 'STOP', which are protected against damage and corrosion from sea water spray.

To operate the engine:

1. Put the switch in 'RUN' position for ten seconds maximum
 - Red lamp for no starter battery charge should function
 - Yellow lamp for low oil pressure should function
 - Green lamp for high engine temperature should not function (when engine is cold / cool / warm). This lamp will only ever function if the engine is over temperature.
 - Buzzer should sound
2. Press 'START' button and hold position until engine fires (see initial start-up section for maximum time starter can be operated). Release button (when engine has started)
 - Red and yellow warning lamps should extinguish and buzzer should stop sounding. The oil pressure lamp may take a few seconds to switch off and the charge fail lamp may remain on until engine rpm is increased to approximately 1,000 rpm if the engine was started at tickover.
3. To stop the engine press the 'STOP' push button, hold in until engine stops. This button also switches the power off to the gauges and engine.
4. Put the switch in 'Off' position
5. To re-start the engine, simply repeat steps from '1' above, there is not need to switch battery isolators off whilst remaining on board.
6. If leaving the boat, isolate start battery from engine and panel, to prevent accidental start up of engine.

ELECTRICAL FAULT FINDING

- Oil pressure & water temperature switch / senders fitted to engine, requiring individual connections for driving gauges & warning lamps.

Note: Water temperature switch / sender (Part number 200-01133)

- large spade is sender connection (brown)
- small spade is switch connection (violet)

Oil pressure switch / sender (Part number 200-62680)

- G Gauge wire (grey)
- M Earth (black)
- WK Warning lamp (brown)

ELECTRICAL FAULT FINDING – EXTENSION HARNESSSES

Some installations require one of the panel extensions 8 way connectors to be removed to allow the cable to be passed through bulkheads etc. If any panel problems are experienced after this may have been carried out, visually check all 8 way connections on engine harness to

panel extension (and panel extension to instrument panel) to ensure wire colours to each terminal match up to the correct colour in its corresponding terminal. Extra attention must be given to black (ground) and orange (tacho), also red (switched positive to alternator) and

grey (charge fail) as these connections are harder to distinguish between in poorly lit areas. Whilst doing this check integrity of each connection to ensure terminals have not become damaged. Once checked, re-fit cable tie around each connection to keep them secure.

BUKH P/N'S FOR REPLACEMENT ITEMS:

Description	Part number
Control panel	020D2165
Instrument panel	023D2107
Tacho, 0-4000 rpm	552J0911
Oil pressure gauge	552J1007
Water temperature gauge	552J1006
Oil pressure switch / sender	552J0965
Temperature switch / sender	200-01133
Panel Start/stop button	552K0008
On/off switch	552K0211
Red warning indicator lamp (AMP)	552A0357
Yellow warning indicator lamp (OIL)	552A0356
Green warning indicator lamp (TEMP)	552A0355
Distributor board	008E9694
Relay arrangement, cpl.	008E9812
Start relay 12V 40A	612E0120
Relay 12V	612F0700
Inversion switch	2178971/G
40 amp blade fuse	552A2341
Standard engine harness	008E9642
2 m panel extension loom	020D2303
10 m panel extension loom	023D2323
Double charging diode	612H0550
Alternator	023D2331
Electric starter	600-00540

Note: the above part numbers are suitable for earth return installations only (where battery negative cable is connected directly to engine ground). For insulated earth (where battery negative cable is isolated from engine ground) different harnesses,

alternators, switches for oil pressure and engine temperature will be required. If your application is wired as insulated earth return and the engine will not operate correctly, always check starter battery negative is connected to the correct terminal

on the isolating solenoid. It should be connected to the terminal which is also used for all the small black wires, **NOT the terminal with the single black wire connected directly to engine ground.**

Spanner torque settings

Tightening Torques for general use bolts and nuts

ITEM	Size x Pitch	kgf.m	ft.lbs	N.m
M6 (7T) : 6mm (0.24in)	–	1.0~1.15	7.2~8.3	9.8~11.3
M8 (7T) : 8mm (0.31)	–	2.4~2.8	17.4~20.3	23.5~27.5
M10 (7T) : 10mm (0.39in)	–	5.0~5.7	36.2~41.2	49.0~55.9
M12 (7T) : 12mm (0.47in)	–	7.9~9.2	57.1~66.5	77.5~90.5

Tightening Torques for special use bolts and nuts

ITEM	Size x Pitch	kgf.m	ft.lbs	N.m
Head Bolts	M11 x 1.25	9.5~10.0	68.7~72.3	93.1~98.0
Bolts, Connecting Bolts	M8 x 1.0	4.5~5.0	32.5~36.2	44.1~49.0
Bolts, Flywheel	M12 x 1.25	10.0~11.0	72.3~79.5	98.0~107.8
Bolts 1, Bearing Case	M9 x 1.25	4.7~5.2	34.0~37.6	46.1~50.9
Bolts 2, Bearing Case	M10 x 1.25	7.0~7.5	50.6~54.2	68.6~73.5
Nozzle Holder Assembly	M20 x 1.5	5.0~7.0	36.2~50.6	49.0~68.6
Caps Nuts, Head Cover	M8 x 1.25	0.7~0.9	5.1~6.5	6.9~8.8
Glow Plugs	M10~1.25	2.0~2.5	14.5~18.1	19.6~24.5
Oil Switch	PT 1/8	1.5~2.0	10.8~14.5	14.7~19.6
Nuts, Rocker Arm Bracket	M8 x 1.25	2.4~2.8	17.4~20.3	23.5~27.5
Bolts, Idle Gear Shaft	M8 x 1.25	2.4~2.8	17.4~20.3	23.5~27.5
Nut, Crank Shaft	M30 x 1.5	14.0~16.0	101.2~115.7	137.3~156.9
Nut, Injection Pipe	M12 x 1.5	2.5~3.5	18.1~25.3	24.5~34.3

Section 3

INSTALLATION RECOMMENDATIONS

The installation details contained herewith are basic guidelines to assist installation, due to great diversity of marine craft it is impossible to give definitive instructions. Therefore Beta Marine can accept no responsibility for any damage or injury incurred during the installation of a Beta Marine Engine whilst following these guidelines.

- All engines shall be placed within an enclosure separated from living quarters and installed so as to minimise the risk of fires or spread of fires as well as hazards from toxic fumes, heat, noise or vibrations in the living quarters.
- Unless the engine is protected by a cover or its own enclosure, exposed moving or hot parts of the engine that could cause personal injury shall be effectively shielded.
- Engine parts and accessories that require frequent inspection and / or servicing must be readily accessible.
- The insulating materials inside engine spaces shall be not combustible.

ENGINE MOUNTING



pillar stud. This will limit vibration and extend the life of the flexible mount. If necessary, fit spacer blocks below the mounts.

A flexible coupling should be fitted. Flexible couplings do not accommodate bad alignment. The mating faces of the gearbox and tailshaft must be checked for alignment, they must be parallel and concentric to within 0.005" (0.127mm).

To ensure vibration free operation, the engine must be installed on substantial beds, extending as far forward and aft as possible and well braced to form an integral part of the hull.

The engine must be installed as low as possible on the flexible mount

WARNING

1. Do not set the engine feet high up the flexible mount pillar stud. This will cause excessive engine movement and vibration. Pack under the flexible mount with steel shims securely bolted into the engine bearer.
2. The pillar stud on the flexible mount is secured into position by the lower locknut, do not forget to tighten this. **Also ensure that the stud is not screwed too far through the mounting body so that it can touch the bearer. This will cause vibration and knocking noises which are very hard to find!!**

ALIGNMENT

Alignment must be checked for parallel (A) and concentric (B) misalignment using a set of feeler gauges.

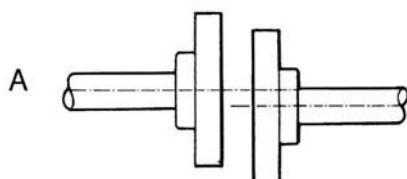

To obtain accurate alignment the flexible mountings must be adjusted until alignment is attained, and the mountings must be locked in position.

Once mounts are tightened, alignment must be re-checked. Coupling can now be fitted in accordance with instructions supplied with coupling.

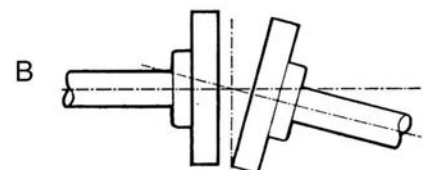

DRY EXHAUST SYSTEM

(a) A correctly installed engine as described in this handbook will meet the exhaust emission requirements of Directive 2003/44/EC amending the Recreational Craft Directive 94/25/EC.

(b) For compliance with exhaust emissions requirements, engines must have correctly installed exhaust systems. To ensure exhaust emissions are kept within permissible limits it is most important to reduce exhaust back pressure to a minimum, whilst ensuring exhaust is adequately muffled. Back pressure increases as exhaust length increases and from bends in the exhaust

system. The exhaust back pressure, measured with the exhaust system connected and the engine running at full speed, must not exceed 80mmHg (3.1inchesHg / 42 inches WG). The correct measuring point is at the position where the exhaust connects to the exhaust manifold. That is before the water injection elbow or dry exhaust bellows.

The exhaust system installed in a canal boat or work boat with a dry exhaust should be $1\frac{1}{2}$ " minimum ID. The engine is fitted with a $1\frac{1}{2}$ " BSP male connector when a dry exhaust system is specified. A flexible exhaust bellows and dry exhaust silencer should

be used. It is up to the installer to work out his own pipe run but care should be taken as follows:

- (1) Ensure that rain water cannot enter the exhaust port and run back down the system, flooding the silencer and eventually the engine.
- (2) The system should be lagged if there is any danger of the crew getting near it.
- (3) A dry exhaust system will give off considerable heat and suitable ventilation must be provided.
- (4) The exhaust back pressure should not exceed 3.1 inches of Hg.

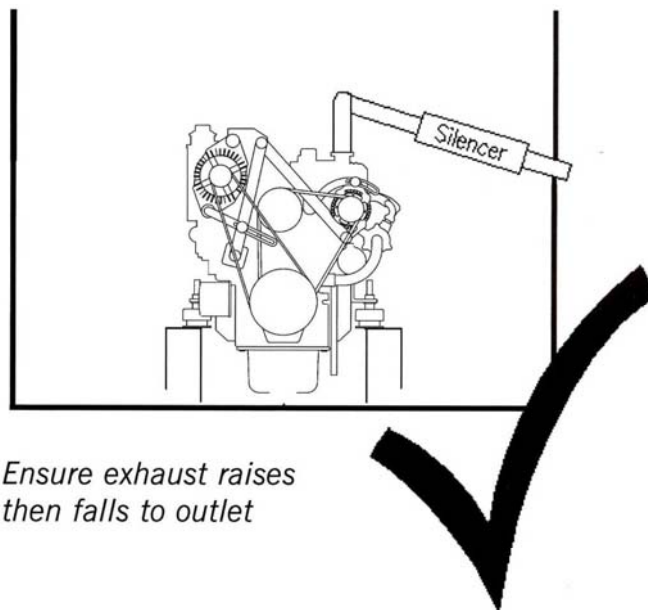
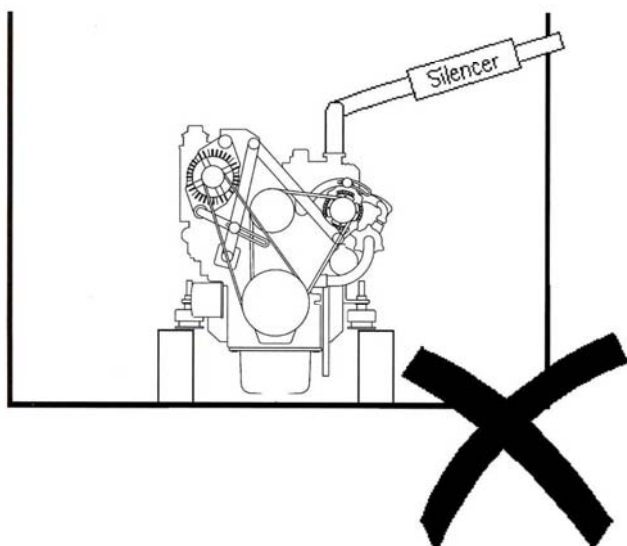

FUEL SUPPLY & LEAK OFF - A typical system is shown below

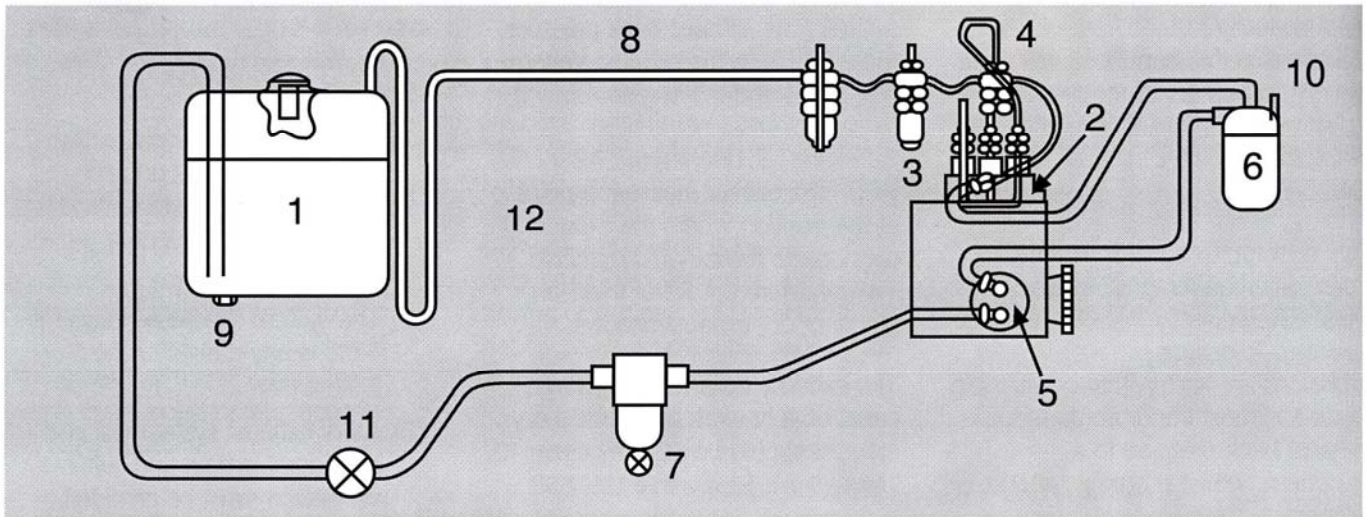

- | | | | |
|----------------------|--|--------------------------|---------------------|
| (1) Fuel tank | (4) Injection pipe | (7) Fuel water separator | (10) Air vent |
| (2) Injection pump | (5) Mechanical fuel feed pump with priming lever | (8) Overflow/leak off | (11) Stop cock |
| (3) Injection nozzle | (6) Fuel filter | (9) Drain plug | (12) Fuel pipe loop |

Notes:

- The mechanical fuel lift pump is fitted to all engines as standard, but if a suction head of 0.25m is required then an electric fuel lift pump must be fitted (ask your dealer or Beta Marine).
- It is very important that the excess fuel from the injectors, is fed back to the fuel tank and not back to any point on the supply line. This will help prevent air getting into the system.
- Any fuel leaks in the system are likely to cause poor starting and erratic running and must be corrected immediately.
- A fuel/water separator must be installed (See 7).
- The fuel return (leak off) pipe must loop down to be level with the bottom of the tank before it enters the top of the tank (see 12). This prevents fuel 'drain down'.
- Fuel lines and hoses must be secured and separated or protected from any source of significant heat. The filling, storage, venting and fuel supply arrangements and installations must be designed and installed so as to minimise the risk of fire and explosion. Flexible fuel hoses connecting the engine to fuel tank supply and return lines must meet the requirements set in standard ISO 7840:1995/A1:2000 and as required by your surveyor / authority.

3. Fuel pipe sizes are:	Supply (mm)	Leak off (mm)
	8	8

KEEL COOLED

1. The supply pipe to the keel cooler should be 28mm bore and the return 34mm bore.
2. The tank size should have a surface area (x) exposed to the sea water or canal water of $(0.25 \times \text{the bhp of the engine}) = \text{sq ft}$ of cooling area required. For canal boats this should be adequately baffled and a vent provided to expel any air. The supply (hot water) goes in at the top of the tank and the return comes out of the bottom. Also refer to cooling tank notes on page 10.

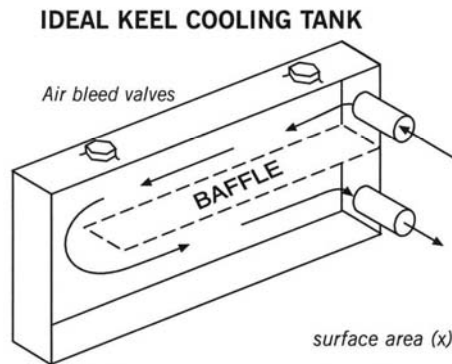

- (1) Baffle continuously welded to outer skin and close fitting on inner skin.
- (2) The tank should be thin in section to allow good mixing of

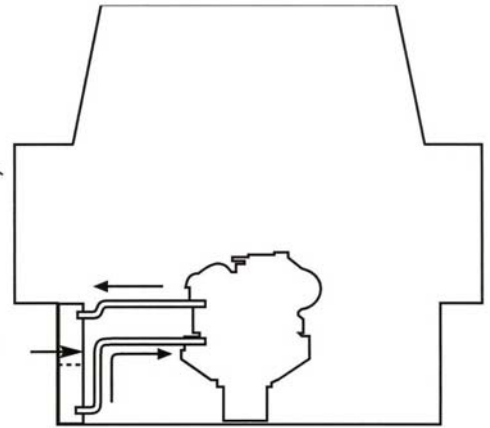

the water over the cool outer surface.

- (3) Air bleed valves should be fitted both ends.

CALORIFIER SYSTEM

All Beta engines can be fitted with the engine tappings to allow the hot water from the closed fresh water/antifreeze system to circulate through a calorifier tank, which in turn heats up domestic water.

Calorifier tappings on this range of engine are shown below.

1. The big problem with a calorifier is to remove all the air from the system. If this is not achieved then they don't work!
2. Try and keep the supply and return pipes a and b either horizontal or sloping down in a continuous fall. This avoids air pockets being created.
3. Extra care must be taken when first filling the calorifier circuit system with 50% antifreeze to water solution as the engine may appear to be full but it soon disappears into the calorifier pipe work. Run the engine off load for 10 minutes then check the level as described in 'Filling The Fresh Water System'.

Also check to see if the pipe going to the calorifier is getting warm after 15 minutes. Top up the water level as required and run for another 10 minutes then repeat.

4. If the water level is steady but no warm water is getting to the calorifier then very carefully open the calorifier bleed valve (see manufacturers instructions) or if none is provided then very carefully loosen the jubilee clip securing the supply pipe to the calorifier. Air should escape. Refasten securely when no further bubbles are seen.

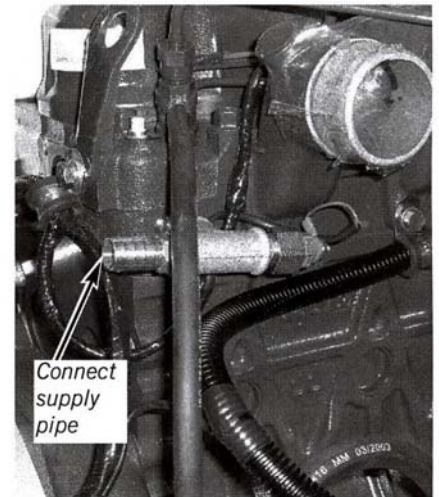

CAUTION

Do not do this when the engine is hot as scalding hot water may be forced out of the pipe under pressure.

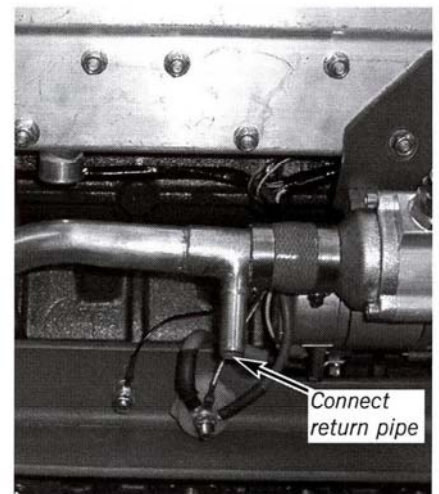

ELECTRICAL INSTALLATIONS

For this range of engines BUKH supply a push button panel.

1. These panels must not be installed where sea water spray can get at them. A suitable flap or cover must be fitted.
2. Panels must be fitted in a location where the helmsman can either see or hear the alarm system.
3. For standard wiring diagrams see following pages.
4. The panels are as standard equipped with 5.5 m cables. As an option, BUKH can provide extension looms for runs of over 5.5 m.
5. All electrical equipment must be protected from sea water. Sea water or rust in the starter will invalidate warranty. Care must be taken when pushing the two halves of the plug together to ensure that individual pins do not push out. To prevent corrosion and assist in assembly we recommend that the plug is packed with petroleum jelly (Vaseline) and then carefully pushed together. The plastic boots should cover both halves and overlap. A cable tie is then put round to hold the two halves in position and help prevent any ingress of water.
6. All cables must be adequately clipped and protected from abrasion.
7. Electrical systems shall be designed and installed so as to ensure proper operation of the craft under normal conditions of use and shall be such as to minimise risk of fire and electric shock.
8. Attention shall be paid to the provision of overload and short-circuit protection of all circuits, except engine starting circuits, supplied from batteries.
9. Ventilation shall be provided to prevent the accumulation of gases, which might be emitted from batteries. Batteries shall be firmly secured and protected from ingress of water.



Control panel



Instrument panel

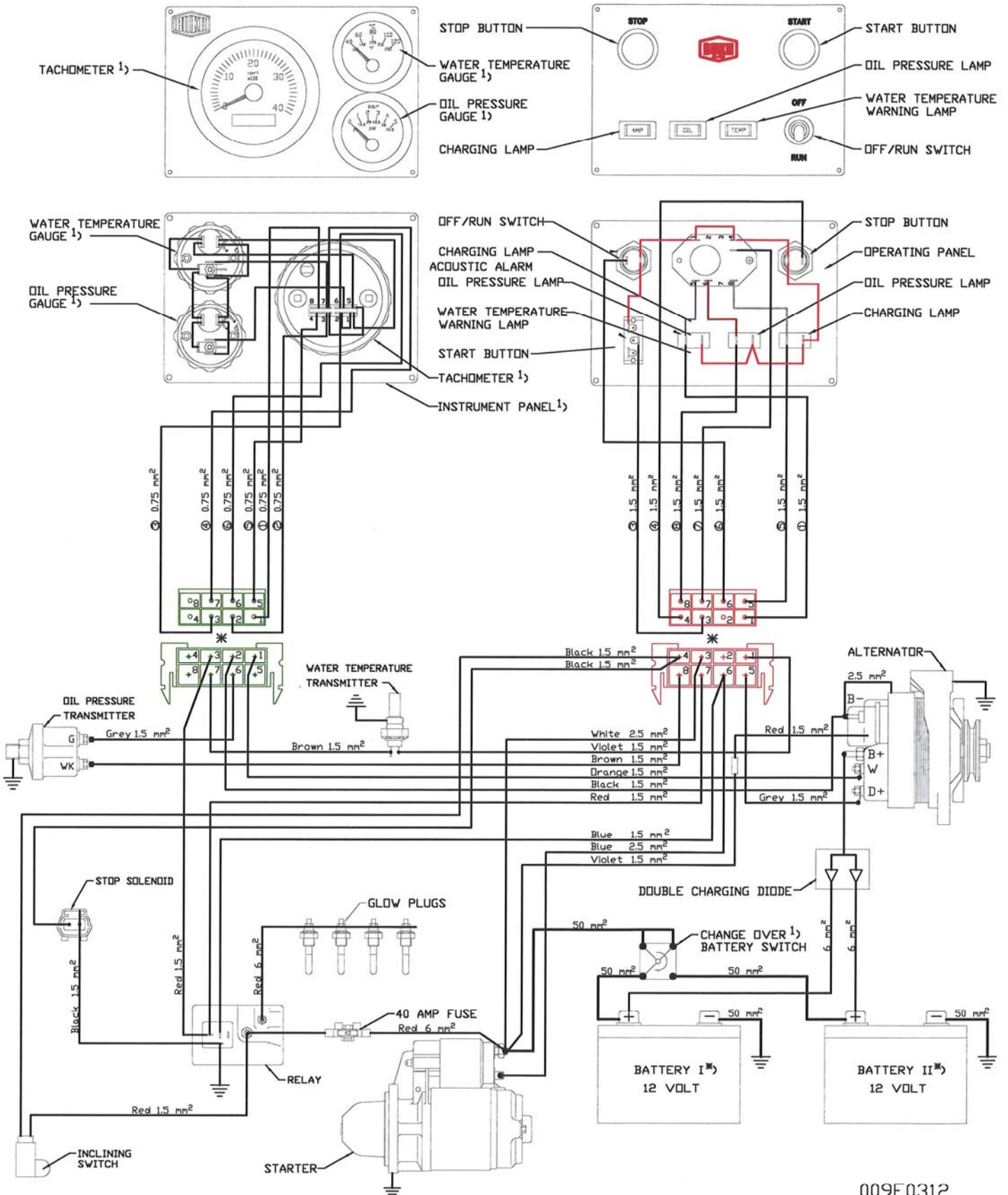



009E0312

NOTE:

The starter must not be operated for more than 10 sec. If further operation is necessary a pause of at least half a minute must be made before starting attempt is repeated.
 Pls. note 'Start instruction' for Life Boat Engines

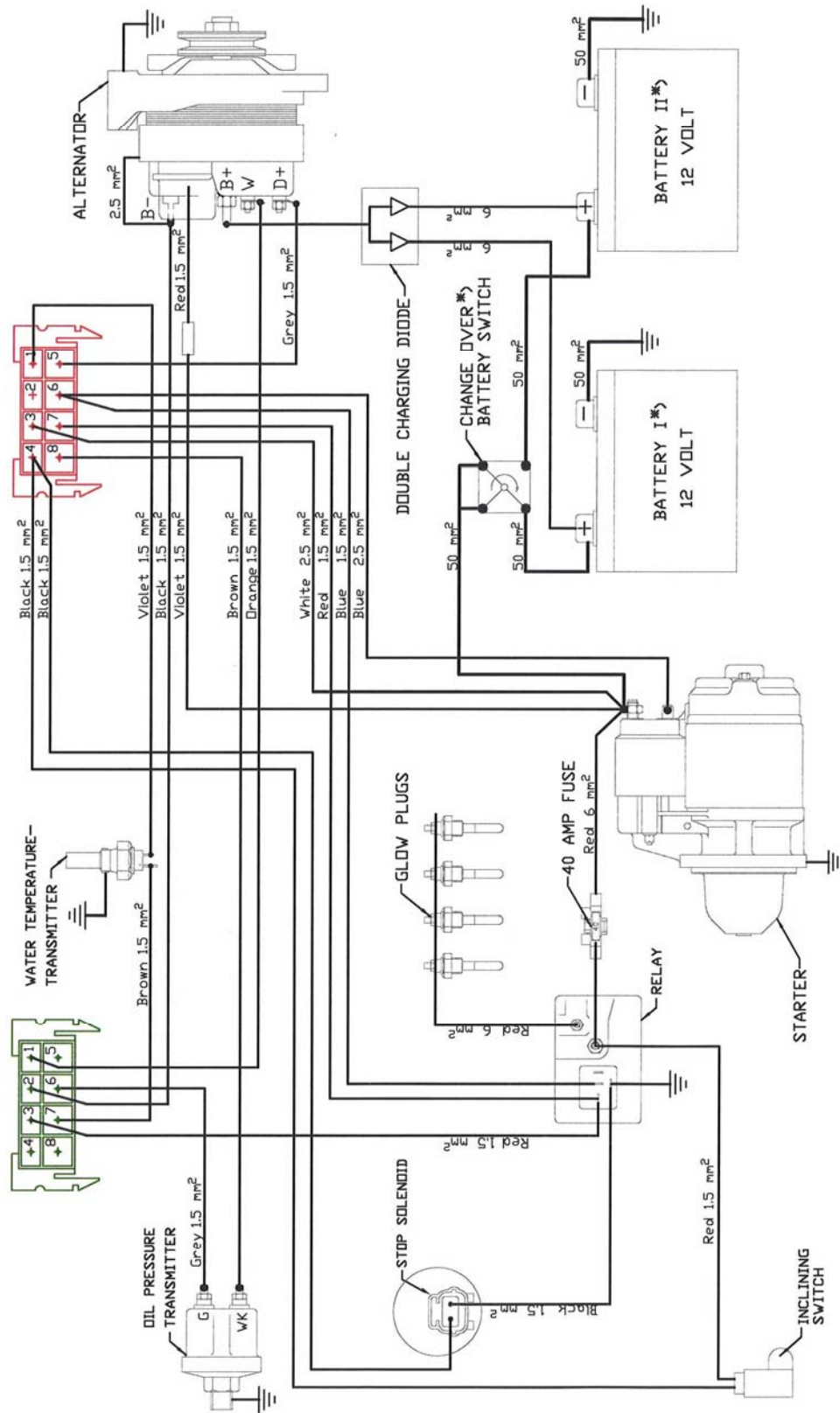
* EXTENSION CABLE CAN BE PLACED HERE
 †) ADDITIONAL EQUIPMENT



 powering marine safety			
ELECTRIC CIRCUIT DIAGRAM			
Engine harness			
A4	Kontrolleret	Tegnet 130220 <i>MS</i>	009E0302

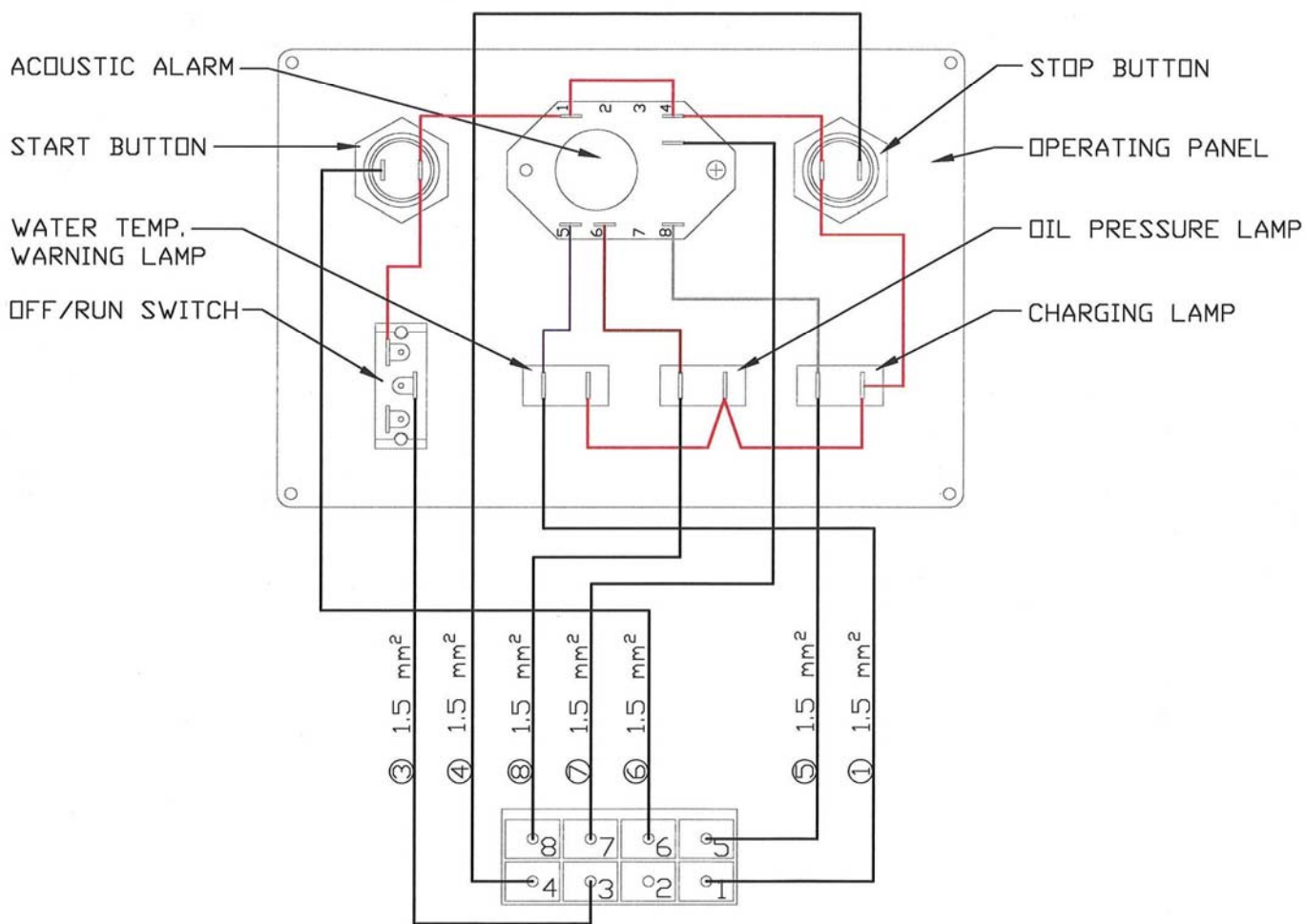
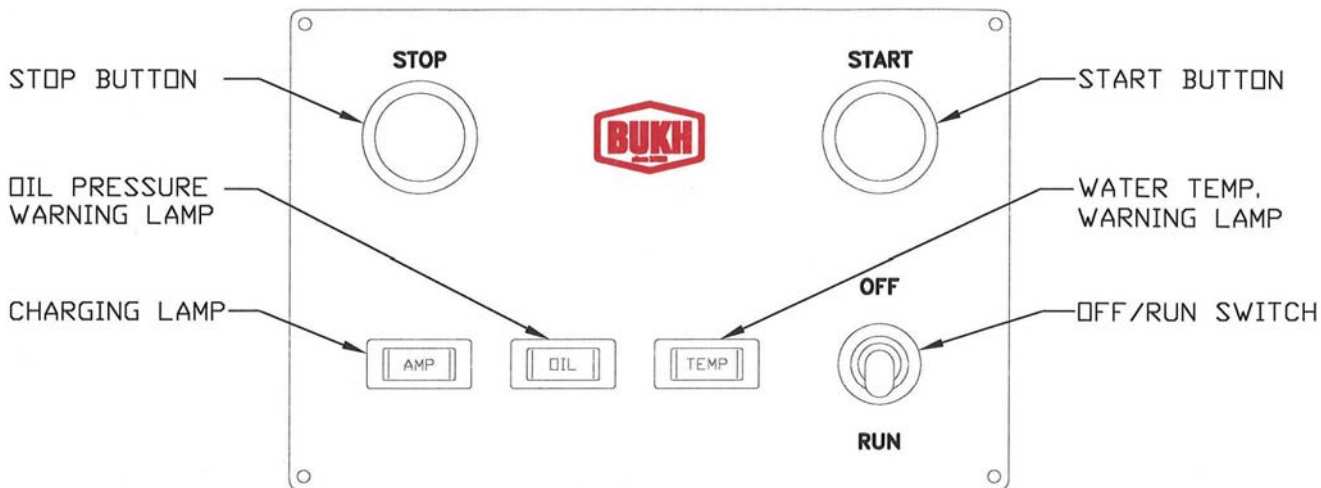

BUKH powering marine safety

ELECTRIC CIRCUIT DIAGRAM

Push Button Starter Panel		
A4	Controlled	Signed
		1302112 <i>MS</i>
		009E0308

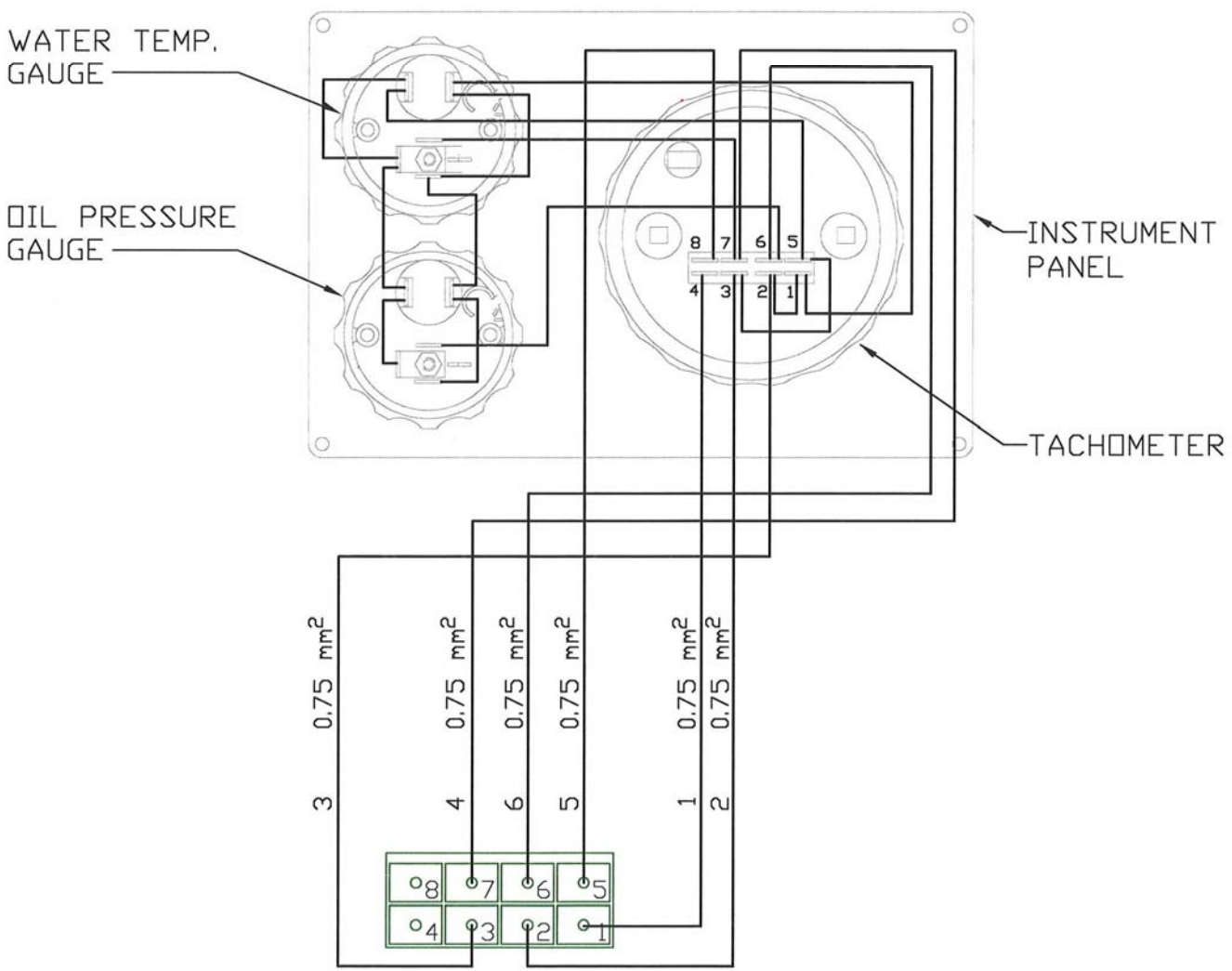
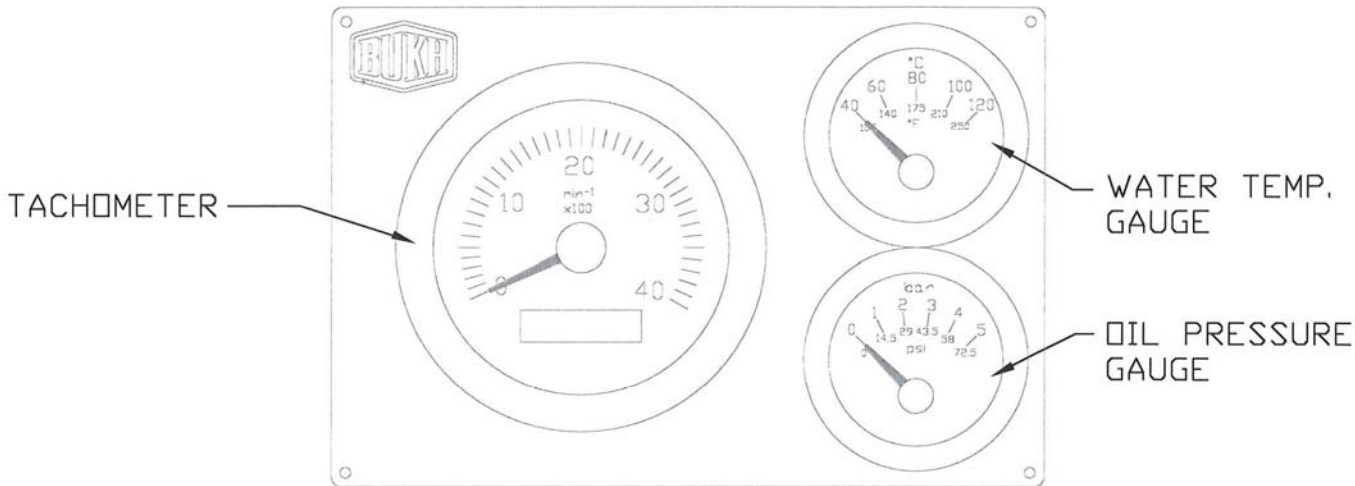

ELECTRIC CIRCUIT DIAGRAM

Instrument Panel 36/48		
A4	Kontrolleret Tegner	110428 <i>ML</i>
		009E0301

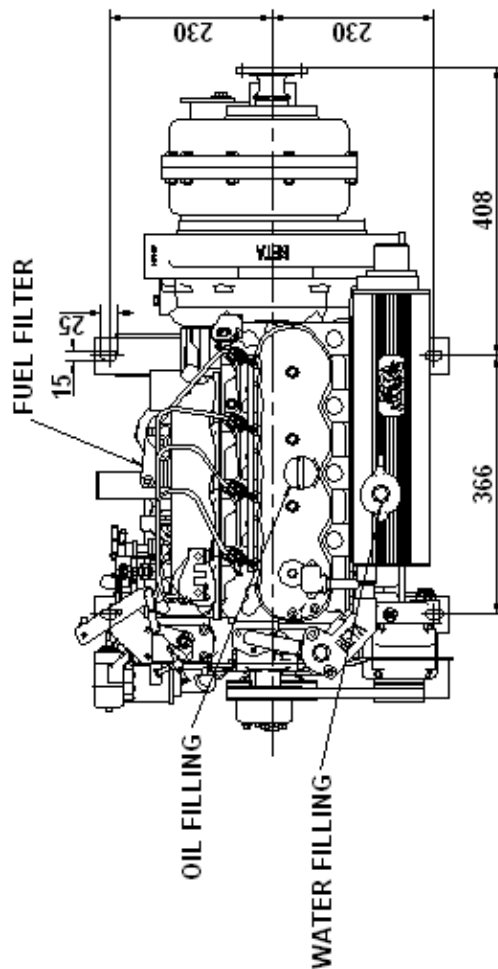
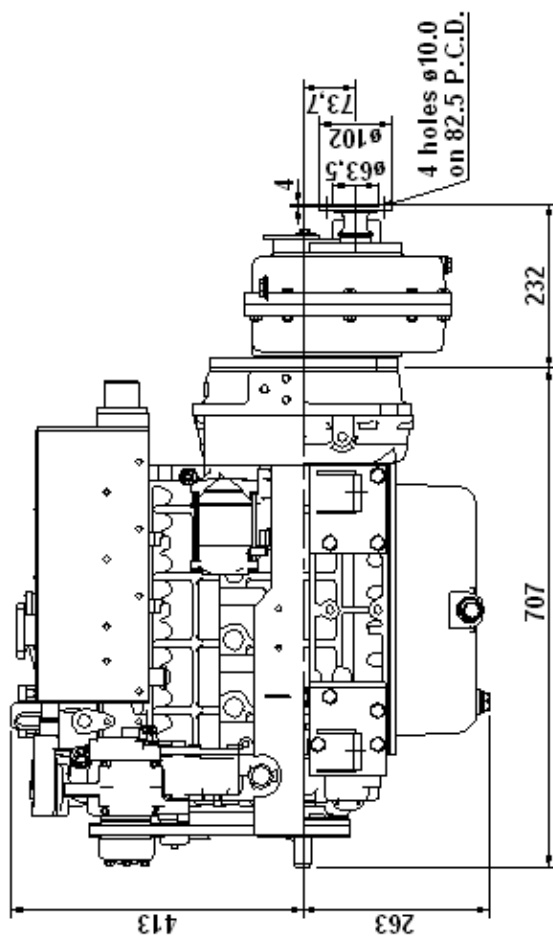
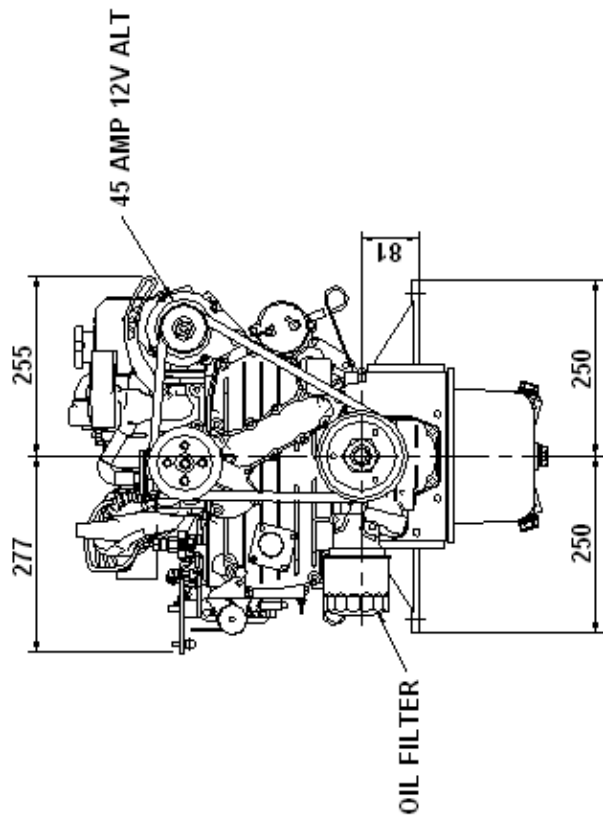

powering marine safety

Diesel engine BBV2203 with PRM150 gear
and keel-cooling

Format	Kontr.	Dato	Tegnet	Scale	Tegn. Nr.	Drwg. Nr.
A2		070308	NL	1:5	009M8501	

Declaration of Conformity for Recreational Craft Propulsion Engine with the Exhaust emission requirements of Directive 94/25/EC as amended by 2003/44/EC
(Completed by manufacturer of inboard engines without integral exhaust)

Name of engine manufacturer: Beta Marine Ltd.
 Street: Merretts Mills, Bath Road Town: Stroud
 Post Code: GL5 5EU Country: U.K.

Engine type-approved according to: **stage II of Directive 97/68/EC**

DESCRIPTION OF ENGINES AND ESSENTIAL REQUIREMENTS

Engine type: Inboard engine.
 Fuel type: Diesel gas oil JIS K2204:1997 or equal.
 Combustion cycle: 4-stroke.

ENGINE(S) COVERED BY THIS DECLARATION	
Engine models and engine family names:	EC Type certificate number (exhaust)
BZ602 Beta 16 BD902 Beta 25 5KBXL898KCB	e1*97/68DA*2002/88*0266*00
BD905 BD1005 Beta 28 BV1305 Beta 35 3KBXL01.3BCD	e1*97/68DA*2001/63*0157*00
BD1105 BV1505 Beta 38 3KBXL01.5BAD	e1*97/68DA*2001/63*0160*00
BD1703 Beta 39 BV1903 Beta 43 BV2203 Beta 50 YKBXL02.2FCD	e1*97/68DA*2001/63*0072*05
BV3300 BV3300T 3KBXL03.3BCD	e1*97/68GA*2001/63*0145*00
BV3800 3KBXL03.8ACD	e1*97/68GA*2001/63*0155*00

Essential requirements	Standards Used	Other normative document used	See technical file
Annex I.B – Exhaust Emissions			
engine identification	N/A	2033/44 annex 1B para 1.	QA025
exhaust emission requirements	N/A	2003/44 para 16, L214/19	Each EC type certificate has its own technical file.
durability	N/A	2033/44 annex 1B para 3.	QA033
owner's manual	BS EN ISO 10240	2033/44 annex 1B para 4.	N/A
Annex I.C – Noise Emissions	see craft manufacturer's Declaration of Conformity		

I declare on behalf of the engine manufacturer that the engine(s) will meet the exhaust emission requirements of Directive 94/25/EC as amended by Directive 2003/44/EC when installed in a recreational craft, in accordance with the engine manufacturer's supplied instructions and that this (these) engine(s) must not be put into service until the recreational craft into which it is (they are) to be installed has been declared in conformity with the relevant provisions of the above mentioned Directive.

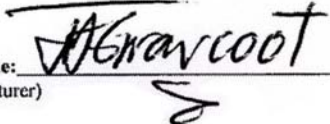
Name: J. A. Growcoat Signature and title:  C. E. O.
 (identification of the person empowered to sign on behalf of the engine manufacturer)

Date: (yr/month/day) 06 / 01 /01.
 Emissions certificate2.doc

Emission durability.

IN RESPECT TO THE RECREATIONAL CRAFT DIRECTIVE 94/25/EC AND AMENDMENT 2003/44/EC ANNEX 1, B3.

The engine must be installed, maintained and operated within the parameters detailed in the Operator's Maintenance Manual. Maintenance must use approved materials, parts and consumables. Should the engine lie unused for a period in excess of 6 months it must be inhibited otherwise it will deteriorate with resulting decrease in performance. See also the Winterising and Laying Up procedures in the Operator's Maintenance Manual.

The fuel settings of the diesel injection system must not be tampered with otherwise the guarantee will be invalid and the performance may fall outside prescribed limit. Such adjustment cannot be allowed under the terms of the emission certification.

Performance of the engine depends upon the use of correct fuels, lubricants and inhibitors. These are fully detailed in the Operator's Maintenance Manual.

Particular attention must be paid to the installation with respect to the exhaust system. The system must be designed so that water cannot back feed into the engine. The run must be such that the back pressure at the engine manifold does not exceed the level detailed in the Operator's Maintenance Manual. Wet, water injected, exhaust systems must be at least the bore mentioned in the Operator's Maintenance Manual and should the run be excessive this bore must be increased accordingly. Back pressure is measured at the outlet of the engine manifold before the water injection bend or dry bellows.

Our experience over 14 years has shown that properly installed and maintained engines hold their performance without major mishap even when running hours exceed those mentioned in the Recreational Craft Directive. It is the owners / users responsibility to ensure that the engine continues to function properly and any malfunction must be immediately investigated. The Trouble Shooting section as detailed in the Operator's Maintenance Manual is particularly helpful in this respect. Engine performance, especially with respect to erratic running, exhaust condition, low power output and high oil consumption are indications of engine conditions that may result in emissions outside the prescribed limits and must therefore be investigated and rectified immediately.

General Terms of Sale and Delivery

1. Introduction

The terms of sale and delivery specified below shall apply to all quotations, orders and consignments unless otherwise specified in any other written agreement.

2. Quotations

Quotations shall be subject to confirmation and the goods being unsold. Aabenraa Motorfabrik reserves the right to change unconfirmed quotations without notice. The prices stated are exclusive of value-added tax and other duties.

3. Orders

Any order shall be confirmed in writing by Aabenraa Motorfabrik in order that an agreement on consignments can be considered as binding.

The order will be delivered at a confirmed price subject to price increases resulting from changes in trade conditions, duties, rates of exchange, raw material supplies and similar conditions.

Cancellation will only be accepted as per arrangement and against payment of expenses incurred.

Illustrations, dimensioned sketches, as well as the contents of leaflets, catalogues, circular letters, etc are approximate and with no binding effect.

When carrying out the order, Aabenraa Motorfabrik reserves the right to make any changes which are deemed necessary from a technical point of view.

4. Terms of Delivery

Delivery will be "ex works" (INCO terms).

Aabenraa Motorfabrik shall not be responsible for delays or obstacles due to force majeure, for example labour conflicts, fires, currency restrictions, shortage of labour and means of transport, general scarcity of goods, restrictions on power and flaws in consignments from sub-suppliers or delay in such consignments, or any other conditions beyond the influence and control of Aabenraa Motorfabrik as well as delay caused by the customer not having supplied sufficient technical information punctually.

If the customer fails to observe the terms stipulated for payment of the purchase price, Aabenraa Motorfabrik shall be under no obligation to make delivery.

Aabenraa Motorfabrik shall not pay any damages for delays in delivery.

5. Packaging

Packaging is included in the price of the product and will not be taken back.

6. Payment

Payment for all consignments shall be made directly to Aabenraa Motorfabrik, Aabenraa, Denmark.

The customer shall not be entitled to withhold payment because of any counterclaims.

If payment should be effected later than the stipulated settling date, interest shall be paid on overdue payments at the rate of 1.5 per cent per month or fraction of a month. Aabenraa Motorfabrik reserves the right to change the rate of interest.

Any consignment shall remain the property of Aabenraa Motorfabrik until payment has been made in full, and the customer must keep the consignment insured against fire and damage - in case of marine plant, against sea risk - at the total new value from the date of shipment from the factory and until full payment has been effected.

7. Remedying Defects

If the consignment should prove defective, Aabenraa Motorfabrik undertakes during the first 24 months after the consignment has been put into service, however, not beyond 30 months from the day the consignment is reported to be ready for shipment, in the case of spare parts, however, 3 months from shipment, to remedy defects which are due to faulty design, materials or workmanship. However, the obligation to remedy defects is conditional on the operating conditions contained or provided in the agreement being observed and the consignment being used and operated correctly.

Defects which are due to 1) improper storage before or during installation, 2) insufficient maintenance, 3) incorrect installation by the customer, 4) changes of the consignment carried out without the written consent of Aabenraa Motorfabrik, 5) incorrect or inexpedient repairs made by the customer or others, 6) normal wear or deterioration, rust, corrosion, deposits caused by water, foreign matter in pipes or the use of unsuitable oils, shall not be covered by Aabenraa Motorfabrik's obligation to remedy defects.

Unless otherwise stipulated, all transport and mounting of defective, repaired and replaced equipment shall be at the customer's account and risk.

Parts of the consignment which are not manufactured by Aabenraa Motorfabrik will only be replaced to the extent that Aabenraa Motorfabrik is compensated for them by the sub-supplier.

Aabenraa Motorfabrik's liability for defects is limited to the above-mentioned obligation. Aabenraa Motorfabrik shall only pay damages if it is proved that the loss caused by the defect is due to gross negligence or intentional circumstances on the part of Aabenraa Motorfabrik. Aabenraa Motorfabrik shall in no circumstances be held liable for operation loss, loss of profits or any indirect damage.

8. Arbitration

Any disputes are to be settled according to Danish law by arbitration in Copenhagen according to the rules of the International Chamber of Commerce and in accordance with the Danish Act on Arbitration of 1972.